

















Machining application	Machining Bearbeitung	Toolholder Klemmhalter	Inserts Stechplatten	Tool's feature and parameters Werkzeug Eigenschaften & Parameter	
External machining · Außenbearbeitung	Parting · Abstechen	"Squirrel Series" QZ**+QE**  A275	ZP*S** 	<ul style="list-style-type: none"> Assemble structure of parting blade and holder, good rigidity and parting range is adjustable. The max. parting $\varnothing = 120\text{mm}$. Die Auskrägung des Abstech-Schwertes ist bei hoher Stabilität einstellbar Der max. Abstech $\varnothing = 120\text{mm}$ 	
		"Squirrel Series" QE**R/L  A272	ZP**D*  ZP*S* 	<ul style="list-style-type: none"> Inserts have 3d chip breaker, small cutting force, good performance on chip breaking maximum parting $\varnothing = 60\text{mm}$ Schneideinsatz mit 3 versch. Spanleitstufen für geringe Schnittkräfte & gute Spankontrolle. max. Abstech $\varnothing = 120\text{mm}$ 	
		Complementary series QZQ*R/L  A286	ZQMX** 	<ul style="list-style-type: none"> Cutting edge strength is suitable for bad machining conditions The maximum parting $\varnothing = 70\text{mm}$ Stabile Schneidkante für den Einsatz bei ungünstigen Bearbeitungsbedingungen Der max. Abstech $\varnothing = 70\text{mm}$ 	
	Grooving and turning Stechen und Drehen	 A247	"Squirrel Series" QE*R/L  A247	Double / Doppelseitig ZT*D**  Profile turning/ Profildrehen ZR*D*  Single cutting edge for deep grooving/ Einseitig ZT*S* 	<ul style="list-style-type: none"> Various applications can be realised by one single tool, installed with different inserts for grooving, profiling and parting, It reduces the tool category. Installed with grooving inserts, the tool realises grooving and transverse cutting. This tool is multifunctional. The max. slot depth = 30mm. Bei Anwendung dieses Universal WZ-System und Verwendung der unterschiedlichen Schneideinsätze können die Bearbeitungen wie; Ab-, Stechen, Profil-, Drehen druchgeführt werden Die max. Nutentiefe = 30mm
			"Squirrel Series" QECD  A273	Precise grooving/ Präzisionsstechen ZT*D**-EG  Edge width 1.2~2.4mm	<ul style="list-style-type: none"> Grinded insert, used for precise grooving. Edge width can be any size between 1.0-6.5mm according to customers requirement. ZT*D**-EG inserts: When edge width is between 1.2-2.4mm, the maximum cutting depth is 2.5mm; When edge width is >2.4~6.5mm, the maximum cutting depth is 22mm
	Precise grooving · Präzisionsstechdrehen	 A272	"Squirrel Series" QE*R/L  A272	Precise grooving/ Präzisionsstechen ZT*D**-EG  Edge width 1.2~2.4mm Stechbreite	<ul style="list-style-type: none"> geschliffene Einsätze für das Präzisionsstechen Die Schneidenbreite kann auf Wunsch zwischen 1.0-6.5mm geschliffen werden. ZT*D**-EG Stechplatte: bei S.-Breiten von 1.2-2.4mm, und max. Schnitttiefe von 2.5mm; bei S.-Breiten von >2.4~6.5mm, beträgt die max Schnitttiefe 22mm









Turning · Drehen

Parting & Grooving Overview · Ab- & Einstechen Übersicht

A

General Turning · Allgemeine Drehbearbeitung

Parting & Grooving · Ab- & Einstechen

Machining application	Machining Bearbeitung	Toolholder Klemmhalter	Inserts Stechplatten	Tool's feature and parameters Werkzeug Eigenschaften & Parameter
External Machining Außenbearbeitung	Grooving Stechen	Complementary series QZS**R/L  A287	ZSMF** 	<ul style="list-style-type: none"> Fine grinded inserts, high precision Cutting edge can be machined 1.1-5.0mm The max. depth of slot = 6mm Geschliffene Einsätze für hohe Präzision Schneidenbreite zwisch. 1,1-5,0mm Die max. Stechtiefe = 6 mm
		Complementary series QT*R/L  A288	154.3** 154.3** 	<ul style="list-style-type: none"> Top and hole clamping Sharp cutting edge, uneasy to shake 3 fine grinded cutting edge, good economic character Used for grooving, the slot width = 1.1-5.5mm The max. cutting depth = 5mm Pratzen- & Lochklemmung Scharfe Schneidkante 3 feingeschliffene Schneidkanten Beim Einstechen beträgt die max. Nutenbreite zwisch. 1,1 - 5,5 mm Die max. Schnitttiefe = 5 mm
Internal machining · Innenbearbeitung	Grooving and turning Stechen und Drehen	"Squirrel Series" C*-Q*R/L*  A284	Grooving, Turning Stechen, Drehen ZT*D**  Profile turning ZR*D** 	<ul style="list-style-type: none"> By installing different inserts for grooving & profiling, one single tool realizes various applications, it reduce the tool category. The max. slot depth can be machined = 13mm The min Ø can be machined = 27 mm Ein W-System für Stech- & Profildrehen. Die Anzahl der Stechsysteme wird reduziert. Die max. Nutentiefe = 13 mm Der min. Ø = 27 mm
	Grooving Stechen	Complementary Series C*-QZSR/L*  A287	Grooving/ Stechen ZSMF**R/L 	<ul style="list-style-type: none"> Fine grinded inserts, high precision Slot width can be machined is 1.1-5.0mm The min. Ø can be machined = 20mm The max. slot depth can be machined = 6 mm Fein geschliffener Einsatz für hohe Präzision Nutentiefe beträgt 1,1-5 mm Der min. Ø = 20 mm Die max Nutentiefe = 6 mm

Turning - Drehen

Parting & Grooving Overview - Ab- & Einstechen Übersicht

Machining application	Machining Bearbeitung	Toolholder Klemmhalter	Inserts Stechplatten	Tool's feature and parameters Werkzeug Eigenschaften & Parameter
Axial Grooving Axial stechen	Grooving and turning Stechen und Drehen	 <p>"Squirrel Series" QF**H A278-A281</p>	Grooving, Turning Stechen, Drehen ZT*D**  Profile turning ZR*D** 	<ul style="list-style-type: none"> By installing different inserts as for grooving and profiling, one single tool realizes various applications, it reduces the tool category. Grooving· Stech Ø 48-400mm Grooving depth· Nuttiefe 10-30mm Ein W-System für Stech- & Profildrehen. Die Anzahl der Stechsysteme wird reduziert.
		 <p>"Squirrel Series" QF**L A282-A283</p>	Grooving, Turning ZT*D**  Profile turning ZR*D** 	<ul style="list-style-type: none"> 90° toolholder, top clamping By installing different inserts as for grooving and profiling, one single tool realizes various applications, it reduce the tool category. Grooving· Stech Ø 48-400mm Grooving depth· Nuttiefe 10-30mm Ein W-System für Stech- & Profildrehen. Die Anzahl der Stech-systeme wird reduziert. 90° Klemmhalter, Pratzenklemmung
Recess Machining Hinterstechen	Recess and turning Hinterstech. und drehen	 <p>"Squirrel Series" *X*D* A273</p>	Grooving, Turning ZT*D**  Profile turning ZR*D** 	<ul style="list-style-type: none"> The unique tool for recess machining Variing recess machining can be realized, inserts programm is complete Ein W-System für Hinterstechdrehen Unterschiedliche Hinterdreheroperationen können durchgeführt werden. Das Einsatzprogramm ist komplett.
Alu profiling Aluminium Profildrehen	External mach. Außenbearbeit.	 <p>"Squirrel Series" QE**R/L A272</p>	"Squirrel Series" ZR**-LH 	<ul style="list-style-type: none"> The unique chip breaker for profiling Al material Cutting edge is designed as combination of sharpness and stability, and it's suitable for continuous to intermittent cut. Used for for external, surface and inner wall machining of Al wheelboss. Spezielle Spanbrecher für die Alu Bearbeitung. Schneidkante besitzt Schärfe und Stabilität für kontinuierlichen bis unterbrochenem Schnitt. Profildrehen, von Alu. Felgen
	Inner wall and surface machining Plan- & Längsprofildrehen	 <p>"Squirrel Series" C40X* A284</p>		<ul style="list-style-type: none"> Used for for external, surface and inner wall machining of Al wheelboss. Spezielle Spanbrecher für die Alu Bearbeitung. Schneidkante besitzt Schärfe und Stabilität für kontinuierlichen bis unterbrochenem Schnitt. Profildrehen, von Alu. Felgen
Tools for aviation and aerospace industries Werkzeuge für die Raum- & Luftfahrt	External machining Außenbearbeitung	 <p>"Squirrel Series" QE*S*N A274</p>	"Squirrel Series" ZIGQ**  "Squirrel Series" ZIMF** 	<ul style="list-style-type: none"> V type locating, top clamping, precisely locating, safely clamping Inserts are suitable for difficult to machine materials like: Ni-base, Ti alloy, Stainless steel and Exotic material. V Form Aufnahme, Top Klemmung für Präzisions-Einsatz, Fixierung & sichere Klemmung Stechplatte für schwierig zu zerspanende Werkstoffen wie: Ni-base, Ti alloy, Stainless steel and exotic material.
	Non-standard Tools Sonderwerkzeug	 <p>Non-Standard tools , Sonderwerkzeug</p>	Select and manufacture according to requirement. Auswahl nach Anwendung	<ul style="list-style-type: none"> Instantly supply solutions for machining various parts to satisfy your machining requirement. Sonderwerkzeuglösungen für die Bearbeitung unterschiedlicher Werkstücke.

A

General Turning · Allgemeine Drehbearbeitung

Parting & Grooving · Ab- & Einstechen



-MG Chip breaker Spanbrecher

■ **Reduction of tool cost by using one special design insert in various.**

- One insert fits to several tool holders
- One insert suitable for several applications
- Reduction of tool cost and warehouse charges

■ **Reduzierung der Werkzeugkosten mit dem Einsatz nur einer Stechgeometrie für viele Anwendungsbereiche.**

- Stechplatte paßt auf versch. Haltersysteme
- Stechpl. geeignet für versch. Bearbeitungen
- Reduzierung der Werkzeug- und Lagerkosten

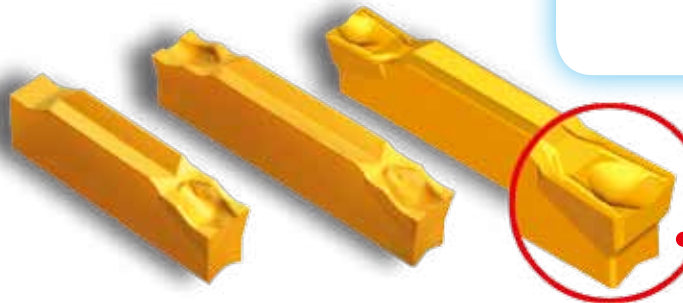

■ **Universal -MG chip breaker series**

Suitable for parting, grooving, profiling and turning etc; good chip control, surface quality and low cutting force

■ **Universelle -MG Spanbrecherserie**

Einsetzbar zum Stechen, Abstechen, für die Profil- und Drehbearbeitung, Gute Spankontrolle.

Gute Oberflächengüten und niedrige Schnittkräfte.

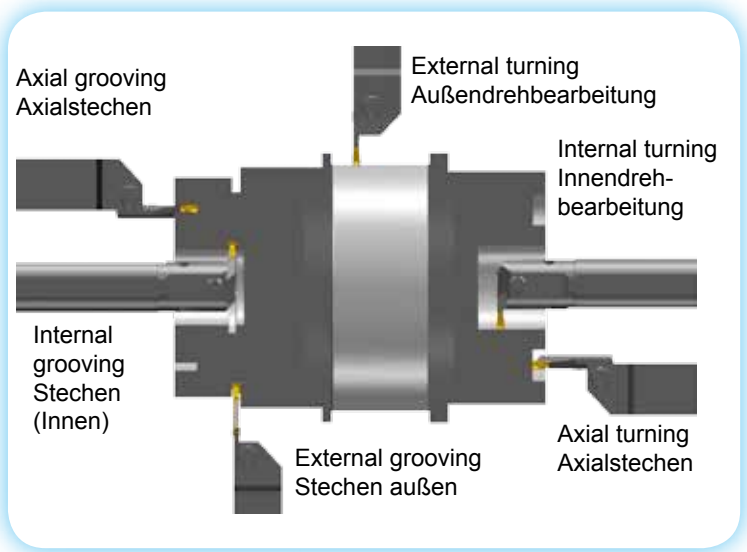

■ **Special design reduce vibration and cutting force 20%**

Spezielles Spanbrecherdesign reduziert Vibrationen und Schnittkräfte um 20%

■ **Unique structure design of parting inserts**

- A special flank structure is designed to reduce cutting force by 20% and diminish shake, which improve the surface quality
- A special edge design requires less rigidity of machine, it can be used on machine with small power

■ **Einzigartiges Schneidkantendesign für AbStechplatte**

- Spezielle Flankenstruktur reduziert die Schnittkräfte um 20%, verhindert Vibrationen und verbessert die Oberflächenqualität
- Eine neu entwickelte Schneidkantenausführung ermöglicht auch den Einsatz auf leistungsschwachen Maschinen.



-EG

Precise grooving, profiling & turning inserts

Special chip breaker design, suitable for precision machining of low-carbon steel, stainless steel, adhesive materials and nonferrous metal.

Präzisions Platten für die Stech-, Profil- & Stechdrehbearbeitung

Spezielles Spanbrecherdesign für die Präzisionsbearbeitung von niedriglegiertem Stahl, rostfreiem Stahl, abrasiven Materialien und Ne-Metallen.

The edge width between

1.0-6.5mm according to your requirement.

Stechbreiten von **1.0-6.5 mm** je nach Anforderung.

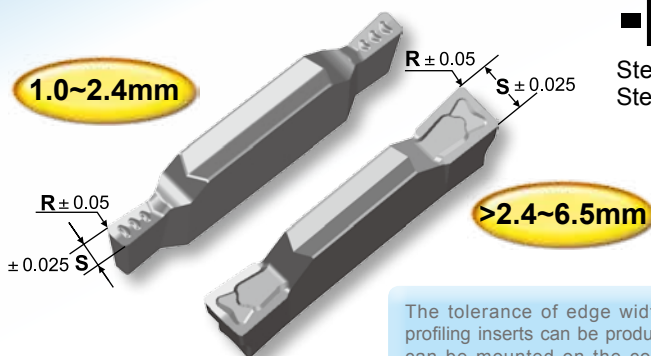

-EG Precision profiling and turning inserts

"Squirrel Series" round Inserts for precision, turning and grooving

-EG Präzisions, Profil- & DrehStechplatte

Stechplatte mit Rundprofil für die Profil, Drehstech- und Stechbearbeitung

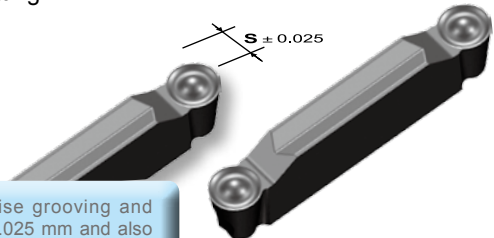

The tolerance of edge width S of precise grooving and profiling inserts can be produced up to ± 0.025 mm and also can be mounted on the corresponding specifications of original toolholder series.

Die Stechbreite S kann mit einer Toleranz bis $\pm 0,025$ mm produziert werden und auf der Standard Halterserie eingesetzt werden.

Profiling turning inserts for AL Profilstechdrehplatten für Alu

The unique chip breaker for aluminum profiling machining. Cutting edge is designed by combining sharpness and intensity, The special chip breaker structure which effectively reduces the frictional coefficient between chips and rake face, enable the inserts suitable for continuous and intermittent profiling Al alloy Machining.

Das einzigartige Spanbrecherdesign für die Profilbearbeitung von Aluminium verbindet eine scharfe Schneidkantenausführung und gleichzeitige Stabilität. Die spezielle Form verhindert die Aufbauschneidenbildung und ist für die Bearbeitung im glatten und leicht unterbrochenem Schnitt einsetzbar.



Turning · Drehen

Parting & Grooving Code Key · Ab- & Einstechen ISO Kennzeichen

Parting, Grooving, Profiling and Turning Code Key

Kennzeichnung für Ab- und Einstechen, Profildrehen und Drehen

Application of insert <i>Anwendung</i>	Code of insert seat size <i>Plattensitzgröße</i>	Number of cutting edge <i>Anzahl Schneiden</i>	Tolerance class <i>Toleranzklasse</i>												
ZP Parting Abstechen	Corresponding code of toolholder and width of cutting edge. Entsprechender Code des Halters und der Schneidenbreite	S Single cutting edge eine Schneide	M Tolerance class Toleranzklasse												
ZT Grooving and Turning Einstechen und Drehen	<table border="1"> <thead> <tr> <th>Code</th> <th>Height / Höhe</th> </tr> </thead> <tbody> <tr> <td>E</td> <td>2.5</td> </tr> <tr> <td>F</td> <td>3.0</td> </tr> <tr> <td>G</td> <td>4.0</td> </tr> <tr> <td>H</td> <td>5.0</td> </tr> <tr> <td>K</td> <td>6.0</td> </tr> </tbody> </table>	Code	Height / Höhe	E	2.5	F	3.0	G	4.0	H	5.0	K	6.0	D Double cutting edges Zwei Schneiden	E Tolerance class Toleranzklasse
Code	Height / Höhe														
E	2.5														
F	3.0														
G	4.0														
H	5.0														
K	6.0														
ZR Profile machining Formdrehen															

ZP G D 04 04 - M G

Width of cutting edge
Schneidplattenbreite



025 = 0.25 mm
03 = 0.30 mm
04 = 0.40 mm
05 = 0.50 mm
06 = 0.60 mm

Corner radius
Eckenradius

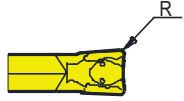

02 = 0.20 mm
03 = 0.30 mm
04 = 0.40 mm
08 = 0.80 mm

Chip breaker's code
Spanbrecher

G
 General chip breaker, suitable for all kinds of machined material.
 Allgemeiner Spanbrecher, geeignet für verschiedene Materialien.

Special chip breaker
F *Sonder Spanbrecher*

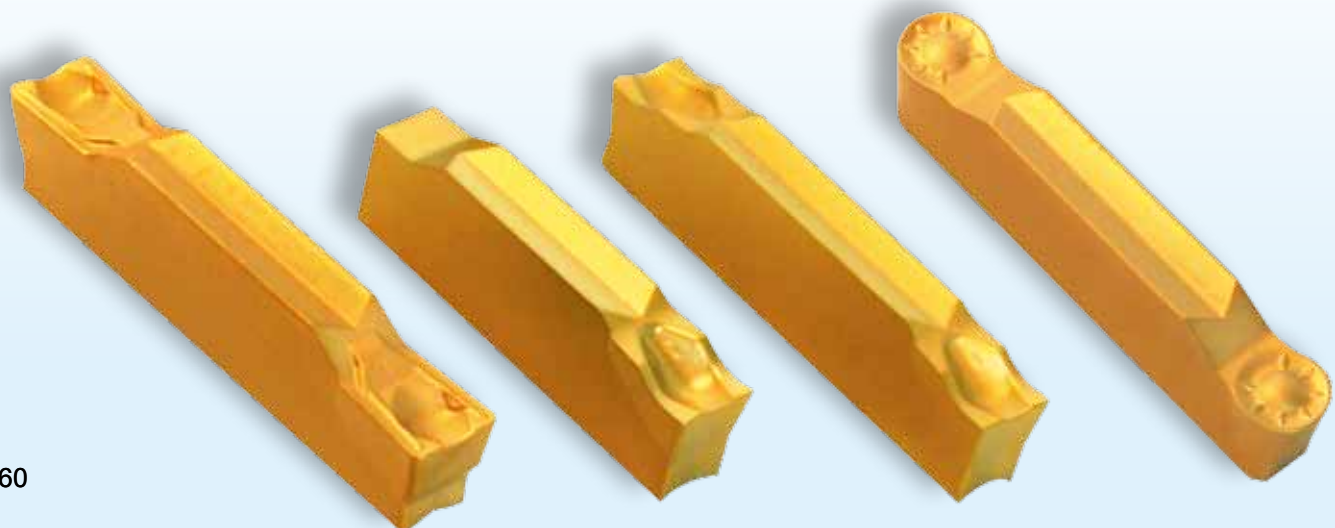

Parting inserts · Stechplatte

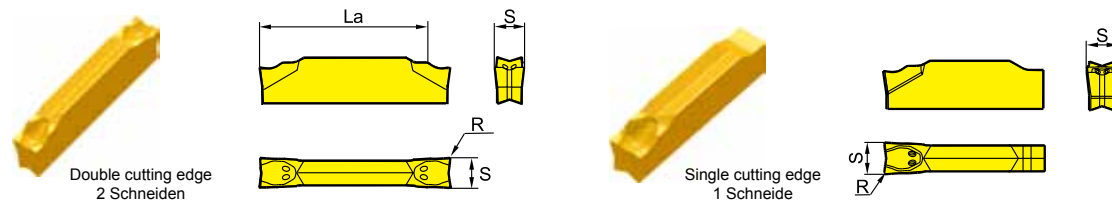

Type · Typ		Dimension (mm) Abmessung			Grade · Sorte						
					P			M		K	N
S ^{+0.1} ₀	R±0.1	La _{max}	YBG202	YBG302	YBC251	YBG202	YBG302	YBG302	YD101		
			Double cutting edge 2 Schneiden	ZPED02502-MG	2.5	0.2	17	●	●	●	●
ZPFD0302-MG	3.0	0.2		17	●	●	●	●	●		
ZPGD0402-MG	4.0	0.2		22	●	●	●	●	●		
ZPHD0503-MG	5.0	0.3		22	●	●		●	●		
ZPKD0604-MG	6.0	0.4		22	●	●	●	●	●		
Single cutting edge 1 Schneide	ZPES02502-MG	2.5	0.2		○	●	●	○	●	●	
	ZPFS0302-MG	3.0	0.2		○	●	○	○	●	●	
	ZPGS0402-MG	4.0	0.2		○	●	○	○	●	●	
	ZPHS0503-MG	5.0	0.3		○	●	○	○	●	●	
	ZPKS0604-MG	6.0	0.4		●	●		●	●	●	

Insert with single cutting edge only be used to parting blad
Zum Abstechen nur mit Spannblock

Please reduce the feed rate by 30% when the insert is approaching the centre of workpiece.

Für eine längere Standzeit der Wendschneidplatten, reduzieren Sie bitte den Vorschub um 30%, wenn die Platte sich dem Zentrum nähert.

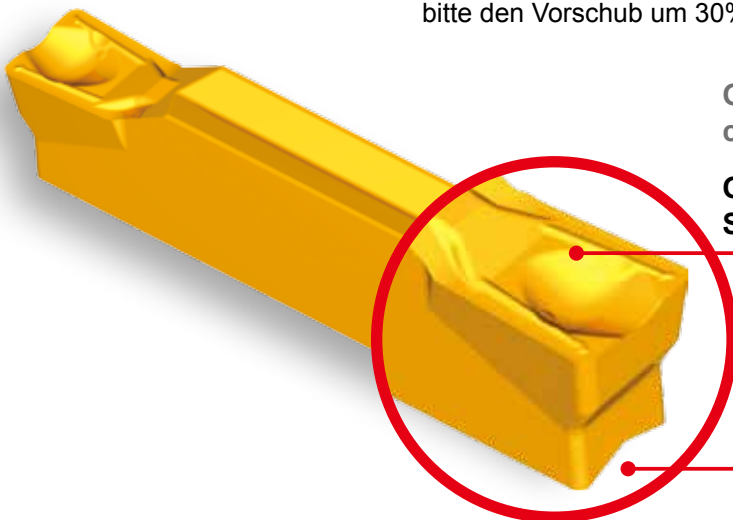

Optimal chip breaker design for good chip control.

Optimaler Spanbrecher für eine gute Spankontrolle.

Cutting force is reduced by 20% less vibration.
Reduziert die Vibrationen und die Schnittkraft um 20%

● ex stock · ab Lager ○ on demand · auf Anfrage

Turning · Drehen

Parting & Grooving · Ab- & Einstechen

ZP*D-MG Series

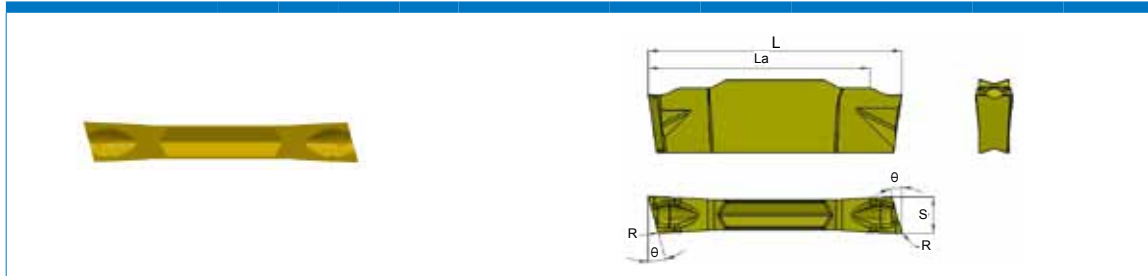

Type · Typ	Dimension (mm) Abmessung					Grade · Sorte						
						P			M		K	N
	L	S	θ	R	La _{max}	YBG202	YBG302		YBG202	YBG302	YBG302	YD101
ZPED02502-MG-6L	20	2.35	6	0.2	17	●	●		●	●	●	○
ZPED02502-MG-6R	20	2.35	6	0.2	17	●	●		●	●	●	○
ZPED02502-MG-15L	20	2.35	15	0.2	17	●	●		●	●	●	○
ZPED02502-MG-15R	20	2.35	15	0.2	17	●	●		●	●	●	○
ZPFD0302-MG-6L	20	2.85	6	0.2	17	●	●		●	●	●	○
ZPFD0302-MG-6R	20	2.85	6	0.2	17	●	●		●	●	●	○
ZPFD0302-MG-15L	20	2.85	15	0.2	17	●	●		●	●	●	○
ZPFD0302-MG-15R	20	2.85	15	0.3	17	●	●		●	●	●	○

ZTBD-MG Series

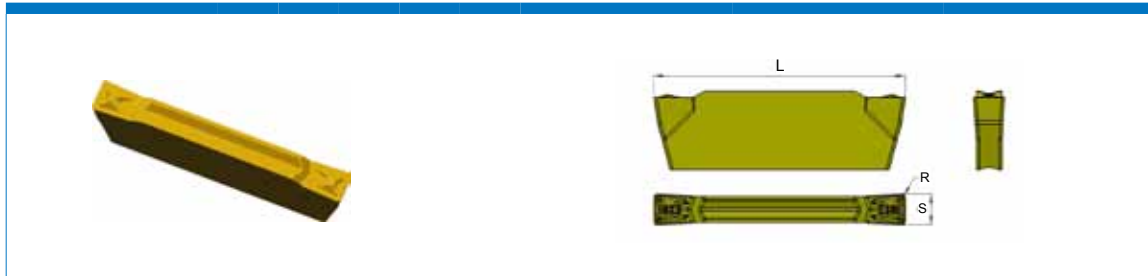

Type · Typ	Dimension (mm) Abmessung					Grade · Sorte		
	L	S ±0.05	R	La _{max}		YBG202	YBG302	
ZTBD02002-MG	16.3	2.0	0.2	13		○	○	

● ex stock · ab Lager ○ on demand · auf Anfrage

Grooving and turning inserts · Einstech- & Drehplatten



Double cutting edge
2 Schneiden

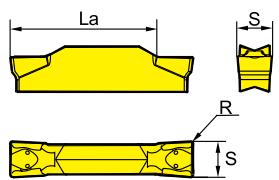

La
S
R



Single cutting edge
1 Schneide

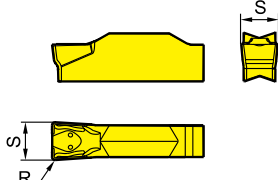

S
R

Type · Typ		Dimension (mm) Abmessung			Grade · Sorte						
					P		M		K	N	
		S ^{+0.1} ₀	R±0.10	La max	YBG202	YBG302		YBG202	YBG302	YBG302	YD101
Double cutting edge 2 Schneiden	ZTED02503-MG	2.5	0.3	17	●	●		●	●	●	
	ZTFD0303-MG	3.0	0.3	17	●	●		●	●	●	
	ZTGD0404-MG	4.0	0.4	22	●	●		●	●	●	
	ZTHD0504-MG	5.0	0.4	22	●	●		●	●	●	
	ZTKD0608-MG	6.0	0.8	22	●	●		●	●	●	
Single cutting edge 1 Schneide	ZTHS0504-MG	5.0	0.4		○	●			●	●	
	ZTKS0608-MG	6.0	0.8		○	●			●	●	

Precise grooving and turning inserts · Präzisions Stech- & Drehplatten



1.0~2.4mm

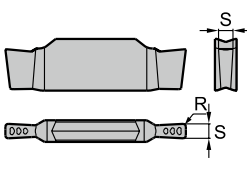

S
R
S



>2.4~6.5mm

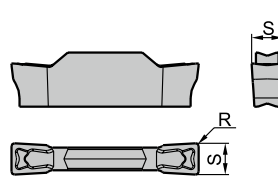

S
R
S

Type · Typ		Dimension (mm) Abmessung			Grade · Sorte						
					P		M		K	N	
		S±0.025	R ⁽²⁾ ±0.05	La max	YBG202	YBG302		YBG202	YBG302	YBG302	YD101
Double cutting edge 2 Schneiden	ZTC****-EG	1.0~1.6	(2)	2.6		○			○		
		1.6~2.4		3.4							
	ZTE****-EG	2.4~3.0		17		○			○		
	ZTFD****-EG	3.0~3.8		17		○			○		
	ZTGD****-EG	3.8~4.8		22		○			○		
	ZTHD****-EG	4.8~5.8		22		○			○		
ZTKD****-EG	5.8~6.5	22		○			○				

Note: (1) The code indicated with * is to be designated based on the edge width and edge radius. The code will be ZTFD03503-EG if the ordered insert is with an edge width of 3.5mm and an edge radius of 3.0mm.

(2) Edge radius R is based on customers' requirements

Der Bestellnummernschlüssel: (1) z.B. ZTFD03503-EG legt ein Schneidbreite 3.5mm und einen Schneideckenradius 0.3mm fest.

(2) Eckenradius nach Kundenwunsch

● ex stock · ab Lager ○ on demand · auf Anfrage

Turning · Drehen

Parting & Grooving · Ab- & Einstechen

Profiling and turning inserts · Profil- & Stechdrehplatten



Type · Typ		Dimension (mm) Abmessung		Grade · Sorte						
				P			M		K	N
Double cutting edge 2 Schneiden		$S^{+0.1}_0$	La_{max}	YBG202	YBG302		YBG202	YBG302	YBG302	YD101
		ZRED025-MG	2.5	20	●	●		●	●	●
	ZRFD03-MG	3.0	20	●	●		●	●	●	
	ZRGD04-MG	4.0	25	●	●		●	●	●	
	ZRHD05-MG	5.0	25	●	●		●	●	●	
	ZRKD06-MG	6.0	25	●	●		●	●	●	

Precise profiling and turning inserts · Präzisions, Profil- & Stechdrehplatten

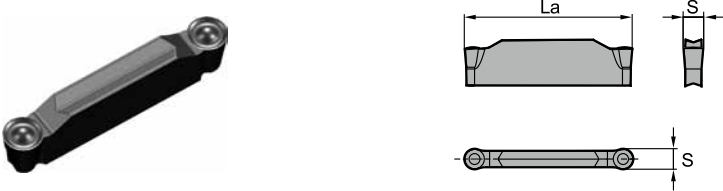

Type · Typ		Dimension (mm) Abmessung		Grade · Sorte						
				P			M		K	N
Double cutting edge 2 Schneiden		$S_{\pm 0.025}$	La_{max}	YBG202	YBG302		YBG202	YBG302	YBG302	YD101
		ZRFD03-EG	3.0	20		○			○	
	ZRGD04-EG	4.0	25		○			○		
	ZRHD05-EG	5.0	25		○			○		
	ZRKD06-EG	6.0	25		○			○		

● ex stock · ab Lager ○ on demand · auf Anfrage

■ **Single-cutting edge grooving and turning inserts for machining of heatresistance super alloy**
Einseitige Stech- & Drehplatten für die Bearbeitung von wärmfesten Superlegierung

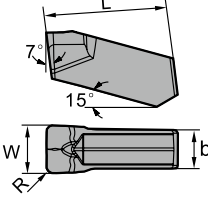
Type · Typ	Dimension (mm) Abmessung				Grade · Sorte			
					S		M	
	W±0.05	R±0.1	b	L	YD101	YBG102	YBG202	YBG202
ZIMF304N-NM	3	0.4	2.4	15.3		●		
ZIMF406N-NM	4	0.6	3.2	15.3		●		
ZIMF506N-NM	5	0.6	4	15.3		●		
ZIMF608N-NM	6	0.8	4	15.3		●		

Turning · Drehen

Parting & Grooving · Ab- & Einstechen

A

General Turning · Allgemeine Drehbearbeitung

- Single-cutting edge grooving and turning inserts for machining of heatresistance super alloy
Einseitige Stech- & Drehplatten für die Bearbeitung von wärmefesten Superlegierungen

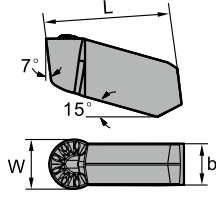
							
Type · Typ	Dimension (mm) Abmessung			Grade · Sorte			
	W±0.025	b	L	S			M
				YD101	YBG102	YBG202	YBG202
ZIGQ3N-NM	3	2.4	15.3		●		
ZIGQ4N-NM	4	3.2	15.3		●		
ZIGQ5N-NM	5	4	15.3		●		
ZIGQ6N-NM	6	5	15.3		●		

- Profiling Inserts for Al · Profilstechdrehplatten zur Aluminiumbearbeitung

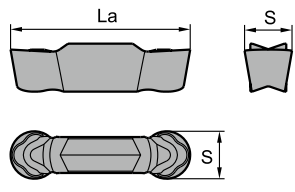
			
Type · Typ	Dimension (mm) Abmessung		Grade · Sorte
	S±0.025	La max	YD101
ZRKD06-LH	6.0	25	●
ZRLD08-LH	8.0	30	●

● ex stock · ab Lager ○ on demand · auf Anfrage

Parting & Grooving · Ab- & Einstechen

154.3 Series

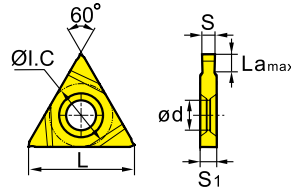

Type · Typ	Dimension (mm) Abmessung						Grade · Sorte						
							P			M			K
	L	I.C	S	S ₁	d	L _{max}	YBC251	YC10	YC40	YBC251	YC10	YC40	YD201
154.3-16110	16.5	9.525	1.1	2.5	4.5	1.2		●	●		●	●	
154.3-16130	16.5	9.525	1.3	2.5	4.5	1.5		●	●		●	●	
154.3-16160	16.5	9.525	1.6	2.5	4.5	1.8		●	●		●	●	●
154.3-16185	16.5	9.525	1.85	2.5	4.5	2.8		●	●		●	●	●
154.3-16215	16.5	9.525	2.15	2.8	4.5	2.8		●	●		●	●	
154.3-16265	16.5	9.525	2.65	3.3	4.5	2.8		●	●				
154.3-16315	16.5	9.525	3.15	3.8	4.5	2.8		●	●		●	●	●
154.3-16415	16.5	9.525	4.15	4.8	4.5	3.0		●	●		●	●	●

ZQMX Series

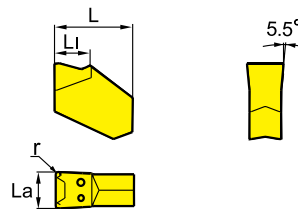

Type · Typ	Dimension (mm) Abmessung				Grade · Sorte						
					P			M			K
	L1	La	r	L	YBC251	YC10	YC40	YBC251	YC10	YC40	YD201
ZQMX3N11-1E	4.4	3.125	0.3	11	●			●			
ZQMX4N11-1E	4.95	4.125	0.3	11	●			●			
ZQMX5N11-1E	5	5.125	0.3	11	●			●			
ZQMX6N11-1E	5.28	6.4	0.3	11	●			●			
ZQMX7N11-1E	4.53	7.05	0.3	14							

● ex stock · ab Lager ○ on demand · auf Anfrage

Turning · Drehen

Parting & Grooving · Ab- & Einstechen

A

General Turning · Allgemeine Drehbearbeitung

Parting & Grooving · Ab- & Einstechen

ZSMF·ZSMX Series

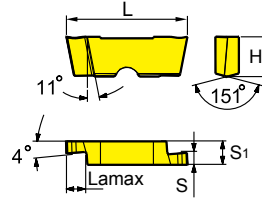

Type · Typ	Dimension (mm) Abmessung					Grade · Sorte		
						P	M	K
	L	S1	H	Lamax	S	YC10	YC10	YD201
ZSMF3110L	16	3.1	5.26	2.1	1.1	●	●	
ZSMF3130L	16	3.1	5.26	2.3	1.3	●	●	
ZSMF3160L	16	3.1	5.26	2.6	1.6	●	●	○
ZSMF3185L	16	3.1	5.26	2.9	1.85	●	●	○
ZSMF3215L	16	3.1	5.26	3.2	2.15	●	●	
ZSMF3265L	16	3.1	5.26	3.7	2.65	●	●	○
ZSMF5500L	22	5.1	6.26	6	5	●	●	
ZSMX8515L	27	8.1	7.26	6.2	5.15			

ZSMF·ZSMX Series

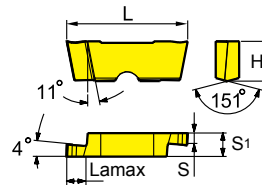

Type · Typ	Dimension (mm) Abmessung					Grade · Sorte		
						P	M	K
	L	S1	H	Lamax	S	YC10	YC10	YD201
ZSMF3110R	16	3.1	5.26	2.1	1.1	●	●	
ZSMF3130R	16	3.1	5.26	2.3	1.3	●	●	
ZSMF3160R	16	3.1	5.26	2.6	1.6	●	●	○
ZSMF3185R	16	3.1	5.26	2.9	1.85	●	●	
ZSMF3215R	16	3.1	5.26	3.2	2.15	●	●	○
ZSMF3265R	16	3.1	5.26	3.7	2.65	●	●	○
ZSMF5500R	22	5.1	6.26	6	5	●	●	
ZSMX8515R	27	8.1	7.26	6.2	5.15			

● ex stock · ab Lager ○ on demand · auf Anfrage

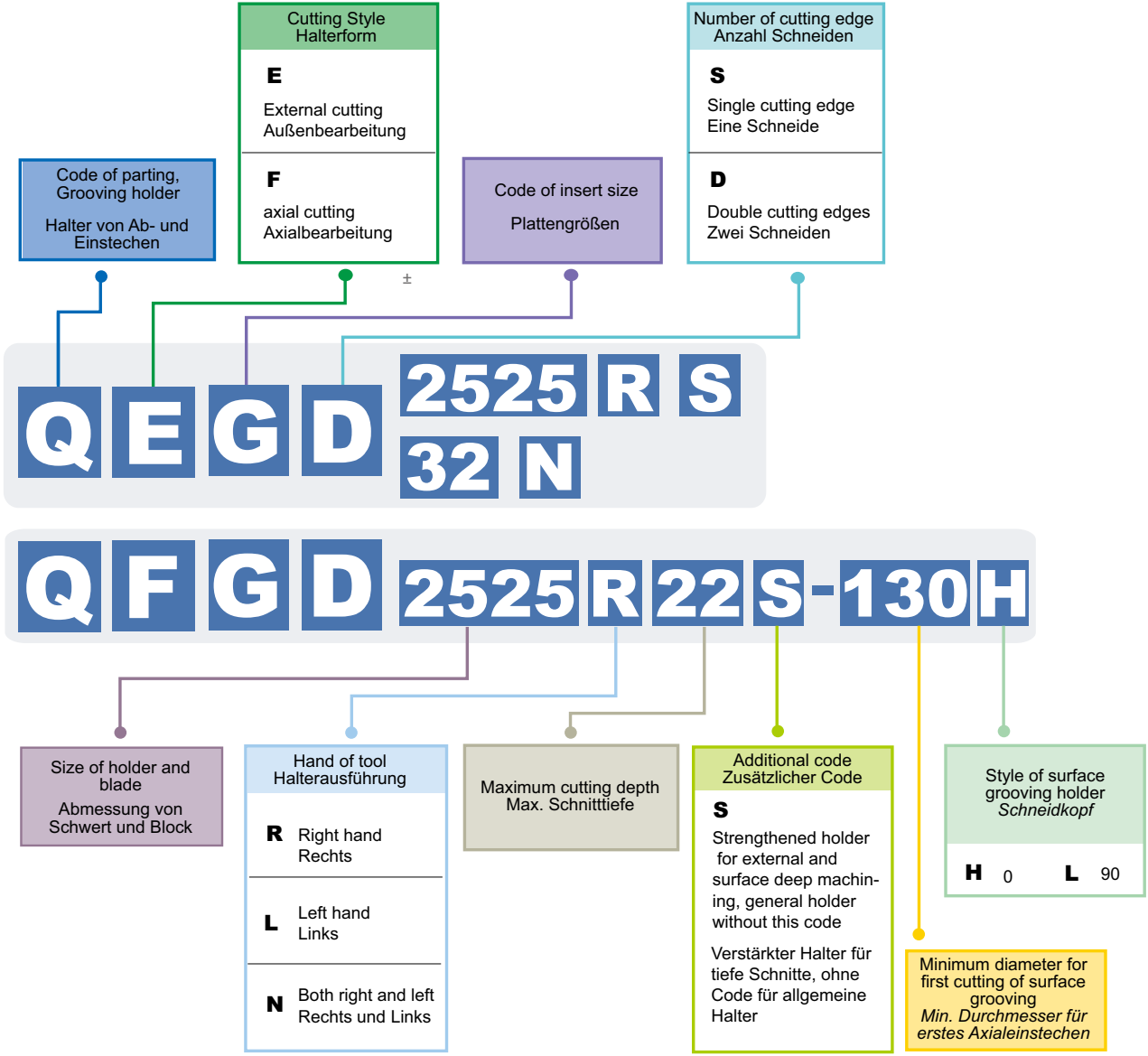

Turning · Drehen

Parting & Grooving Tools Key Code- Ab- & Einstechwerkzeuge ISO Kennzeichen

General Turning · Allgemeine Drehbearbeitung

Parting & Grooving · Ab- & Einstechen

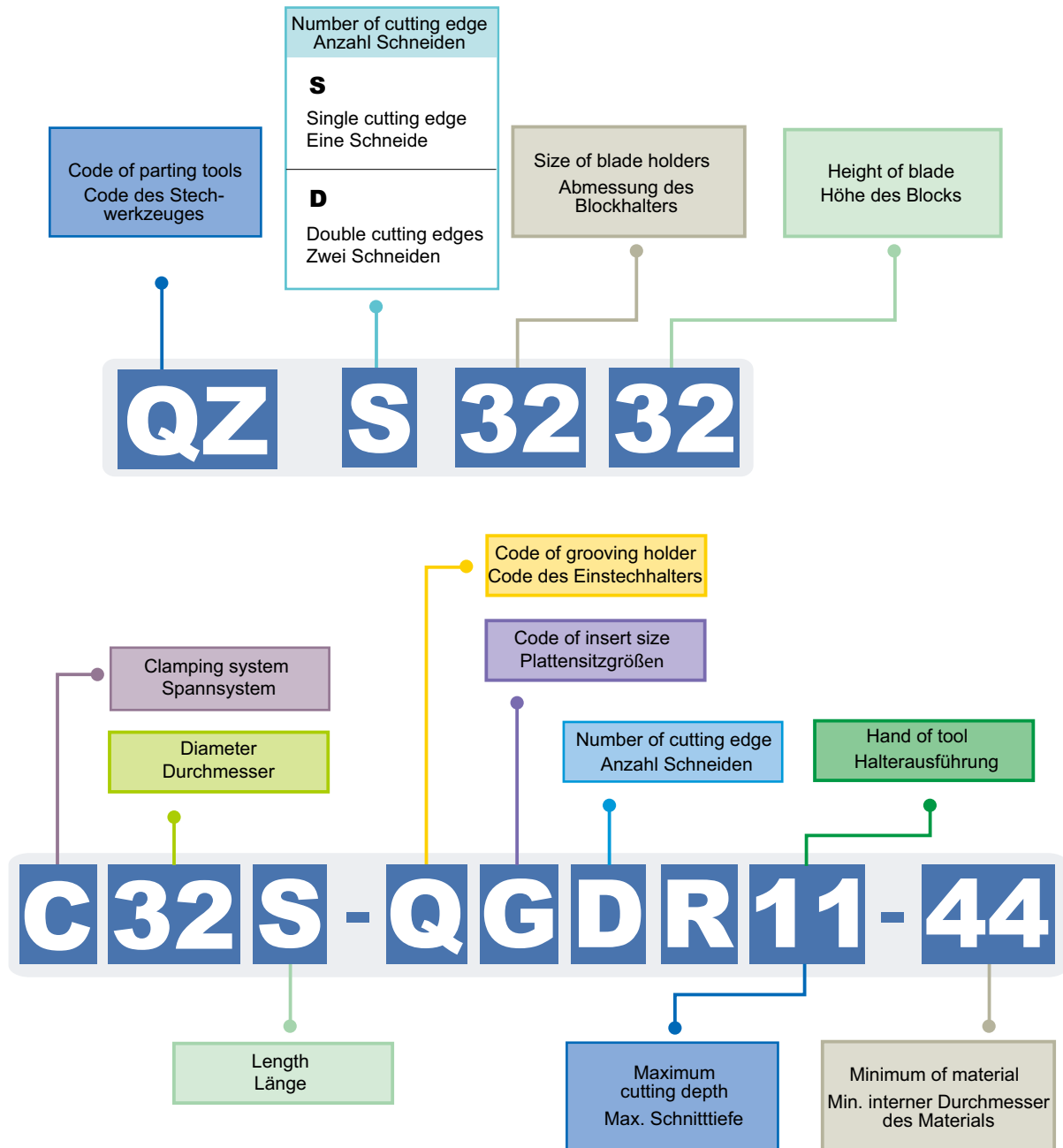

External parting, grooving and turning tools · Einstech- & Drehwerkzeuge (Außen)

Type · Typ		Stock		Dimension (mm) Abmessung					Inserts Stechplatte	Screw Schraube	Wrench Schlüssel
		R	L	H×B	L	S	W	a _r max			
QEBD	2020R/L07	●	●	20×20	150	20.17	2	7	ZTBD02002	M5×16	WH40L
	1616R/L04	●	●	16×16	150	16.17	2	4	ZTBD02002		

External parting, grooving and turning tools · Einstech- & Drehwerkzeuge (Außen)

Type · Typ		Stock		Dimension (mm) Abmessung					Inserts Stechplatte	Screw Schraube	Wrench Schlüssel
		R	L	d	L	S	W	a _r max			
C16M-QBDR/L04-20		●	●	16	150	12	2	4	ZTBD02002-MG	M5×10	WH40L



● ex stock · ab Lager ○ on demand · auf Anfrage

Turning · Drehen

Parting & Grooving · Ab- & Einstechen

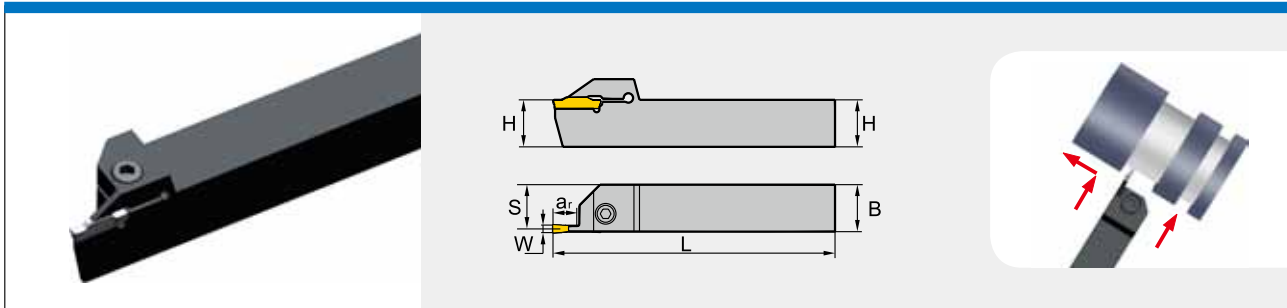
External parting, grooving and turning tools · Einstech- & Drehwerkzeuge (Außen)





Type · Typ		Stock		Dimension (mm) Abmessung					Inserts Stechplatten	Screw Schraube	Wrench Schlüssel		
		R	L	H×B	L	S	W	ar max					
QEED	1616R/L10	●	●	16×16	125	15	2.5	10	Z*ED025**	GB70-85-M5×20	WH40L		
	1616R/L17	●	●	16×16	125	15	2.5	17	Z*ED025**				
	2020R/L10	●	●	20×20	15	10	2.5	10	Z*ED025**				
	2020R/L17	●	●	20×20	25	19	2.5	17	Z*ED025**	GB70-85-M6×20	WH50L		
	2525R/L10	●	●	25×25	150	19	2.5	10	Z*ED025**				
	2525R/L17	●	●	25×25	150	19	2.5	17	Z*ED025**				
QEFD	1616R/L10	●	●	16×16	125	14.8	3	10	Z*FD03**	GB70-85-M5×20	WH40L		
	1616R/L17	●	●	16×16	125	14.8	3	17	Z*FD03**				
	2020R/L10	●	●	20×20	125	18.8	3	10	Z*FD03**				
	2020R/L17	●	●	20×20	125	18.8	3	17	Z*FD03**	GB70-85-M6×20	WH50L		
	2525R/L10	●	●	25×25	150	3.8	3	10	Z*FD03**				
	2525R/L17	●	●	25×25	150	23.8	3	17	Z*FD03**				
QEGD	2020R/L13	●	●	20×20	140	18.5	4	13	Z*FD04**	GB70-85-M6×20	WH50L		
	2020R/L22	●	●	20×20	140	18.5	4	22	Z*GD04**				
	2525R/L13	●	●	25×25	150	23.5	4	13	Z*GD04**				
	2525R/L22	●	●	25×25	150	23.5	4	22	Z*GD04**				
	3232R/L13	●	●	32×32	170	30.5	4	13	Z*GD04**				
	3232R/L22	●	●	32×32	170	30.	4	22	Z*GD04**				
QEHD	2525R/L13	●	●	25×25	150	23	5	13	Z*HD05**	GB70-85-M6×20	WH50L		
	2525R/L22	●	●	25×25	15	23	5	22	Z*HD05**				
QEHS	2525N30	○		25×25	150	12.5	5	30	Z*HS05**				
QEHD	3232R/L13	●	●	32×32	170	30	5	13	Z*HD05**				
	3232R/L22	●	●	32×32	170	30	5	22	Z*HD05**				
QEHS	3232N30	○		32×32	170	16	5	30	Z*HS05**				
QEKD	2525R/L13	●	●	25×25	150	22.6	6	13	Z*KD06**			GB70-85-M6×20	WH50L
	2525R/L22	●	●	25×25	150	22.6	6	22	Z*KD06**				
QEKS	2525N30	○		25×25	15	12.5	6	30	Z*KS06**				
QEKD	3232R/L13	●	●	32×32	170	29.6	6	13	Z*KD06**				
	3232R/L22	●	●	32×32	170	29.6	6	22	Z*KD06**				
QEKS	3232N30	○		32×32	170	16	6	30	Z*KS06**				

● ex stock · ab Lager ○ on demand · auf Anfrage

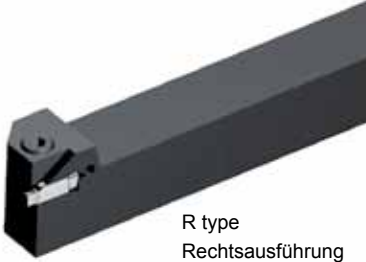

Precise grooving and turning tools · Präzisions Einstech- & Drehwerkzeuge







R type
Rechtsausführung

Type · Typ		Stock		Dimension (mm) Abmessung					Inserts Stechplatten	Screw Schraube	Wrench Schlüssel
		R	L	H×B	L	S	W	a _r max			
QECD	1616R/L025	○	○	16×16	125	14.75		2.5			
	2020R/L025	○	○	20×20	125	18.75					
	2525R/L025	○	○	25×25	150	23.75					





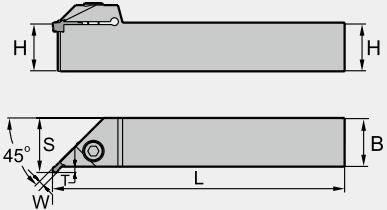

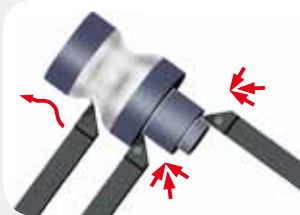





External recess and profiling turning tools · Hinterdrehstech- & Profildrehwerkzeuge (Außen)







R type
Rechtsausführung

Type · Typ		Stock		Dimension (mm) Abmessung					Inserts Stechplatten	Screw Schraube	Wrench Schlüssel
		R	L	H×B	L	S	W	a _r max			
QXFD	2020R/L03-45	○	○	20×20	125	23	3.0	3.0			
	2525R/L03-45	○	○	25×25	150	28					
	3232R/L03-45	○	○	32×32	170	35					
QXGD	2020R/L03-45	○	○	20×20	125	23	4.0	3.0			
	2525R/L03-45	○	○	25×25	150	28					
	3232R/L03-45	○	○	32×32	170	35					
QXHD	2020R/L04-45	○	○	20×20	125	24	5.0	4.0			
	2525R/L04-45	○	○	25×25	150	29					
	3232R/L04-45	○	○	32×32	170	36					
QXKD	2020R/L04-45			20×20	125	24	6.0	4.0			
	2525R/L04-45	○	○	25×25	150	29					
	3232R/L04-45	○	○	32×32	170	36					

● ex stock · ab Lager ○ on demand · auf Anfrage

Turning · Drehen

Parting & Grooving · Ab- & Einstechen

External grooving tools for difficult machining

Stechdrehwerkzeug für die schwierige Bearbeitung (Außen)

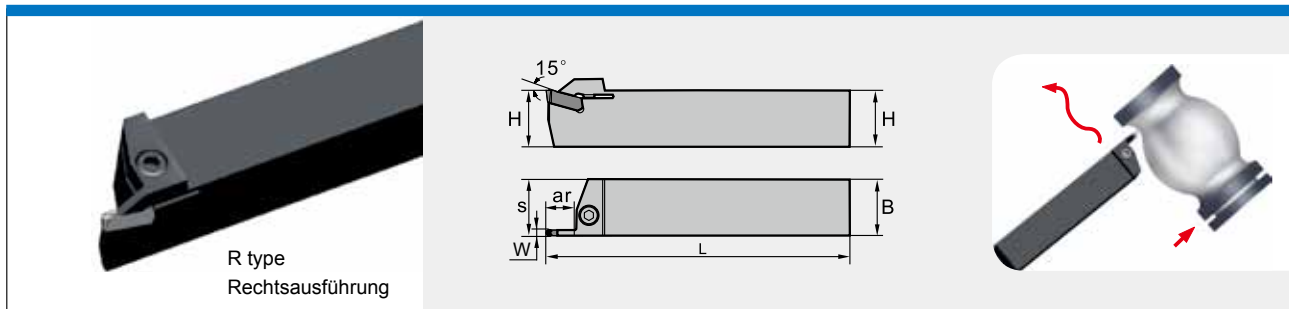

Type · Typ		Stock		Dimension (mm) Abmessung					Inserts Stechplatten	Screw Schraube	Wrench Schlüssel
		R	L	H×B	L	S	W	ar max			
QEFS	2525R/L12-3N	○	○	25×25	150	25.3	3	12	ZIGQ3N-NM ZIMF304N-NM	GB70-85-M6×20	WH50L
	3232R/L22-3N	○	○	32×32	170	32.3	3	22			
QEGS	2525R/L12-4N	○	○	25×25	150	25.3	4	12	ZIGQ4N-NM ZIMF406N-NM		
	3232R/L22-4N	○	○	32×32	170	32.3	4	22			
QEHS	2525R/L12-5N	○	○	25×25	150	25.4	5	12	ZIGQ5N-NM ZIMF506N-NM		
	3232R/L22-5N	○	○	32×32	170	32.4	5	22			
QEKS	2525R/L12-6N	○	○	25×25	150	25.4	6	12	ZIGQ6N-NM ZIMF608N-NM		
	3232R/L22-6N	○	○	32×32	170	32.4	6	22			

● ex stock · ab Lager ○ on demand · auf Anfrage

Blade for external parting · Abstechschwert zur Außenbearbeitung

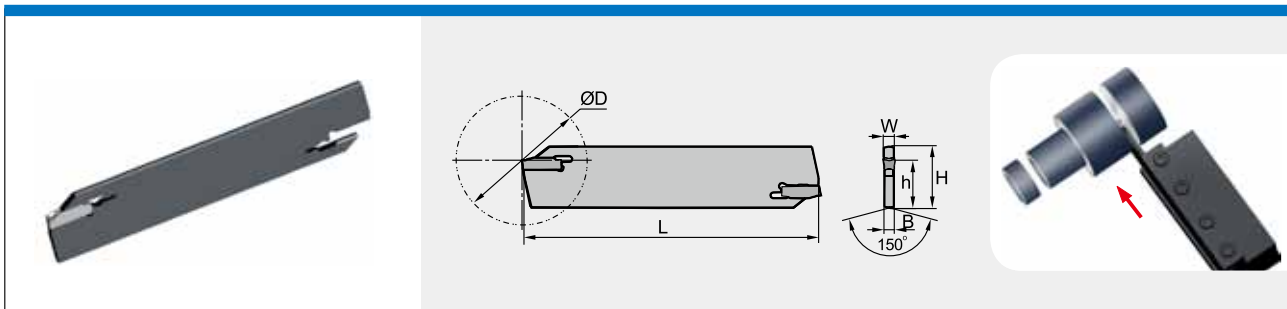

Type · Typ	Stock	Dimension (mm) Abmessung						Inserts Stechplatten	Wrench Schlüssel
		L	H	h	B	W	ØD max		
QEES26N	●	110	26	19	2	2.5	60	ZPES02502-MG	W50RL
QEFS26N	●	110	26	19	2.4	3	60	ZPFS0302-MG	
QEGS26N	●	110	26	19	3.2	4	70	ZPGS0402-MG	
QEHS26N	○	110	26	19	4	5	70	ZPHS0503-MG	
QEKs26N	○	110	26	19	5	6	70	ZPKS0604-MG	
QEES32N	●	150	32	24.6	2	2.5	100	ZPES02502-MG	
QEFS32N	●	150	32	24.6	2.4	3	100	ZPFS0302-MG	
QEGS32N	●	150	32	24.6	3.2	4	120	ZPGS0402-MG	
QEHS32N	●	150	32	24.6	4	5	120	ZPHS0503-MG	
QEKs32N	●	150	32	24.6	5	6	120	ZPKS0604-MG	

Holder for external parting · Spannblock zur Außenbearbeitung

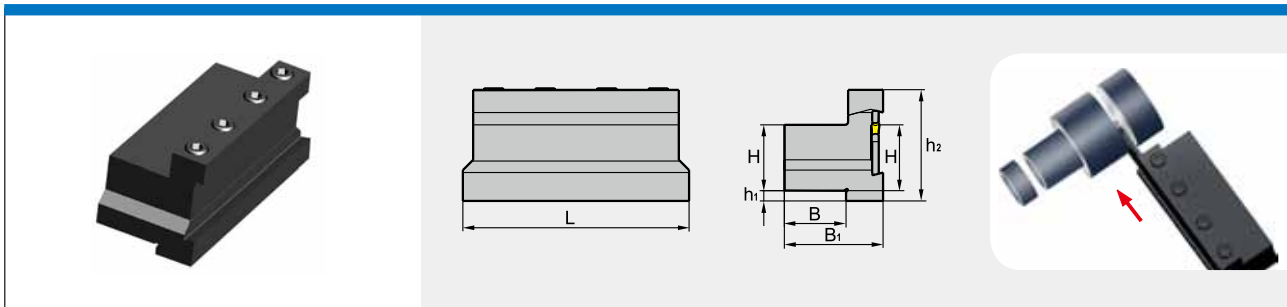

Type · Typ	Stock	Dimension (mm) Abmessung						Clamp Klemme	Screw Schraube	Wrench Schlüssel
		L	H	h ₁	h ₂	B	B ₁			
QZS2026	●	86	20	10	46.6	19	38	QZC26	GB70-85-M6×20	WH50L
QZS2526	●	86	25	5	46.6	23	42	QZC26		
QZS3226	●	86	32	3	51.6	30	48	QZC26		
QZS2032	○	110	20	13	50	19	38	QZC32		
QZS2532	●	110	25	8	50	23	42	QZC32		
QZS3232	●	110	32	5	54	30	48	QZC32		

● ex stock · ab Lager ○ on demand · auf Anfrage

Turning · Drehen

Parting & Grooving · Ab- & Einstechen

■ Axial grooving and turning tools · Axialstech- & Drehwerkzeug



L type
Linksausführung

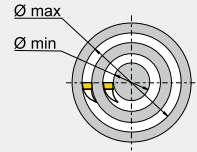
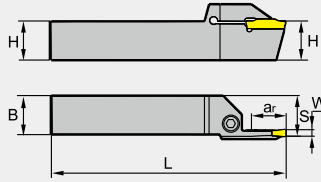

ØD= Range of entering
ØD= Bereich





Type · Typ		Stock		Dimension (mm) Abmessung						Inserts Stechplatten	Screw Schraube	Wrench Schlüssel
		R	L	H×B	L	S	W	ar max	ØD (min-max)			
QFFD	2020R/L7-48H	○	○	20×20	150	21	3	7	48-66	ZTFD0303-MG	GB70-85-M6×20	WH50L
	2020R/L10-48H	○	○	20×20	150	21	3	10	48-66			
	2525R/L10-48H	●	●	25×25	150	26	3	10	48-66			
	2525R/L17-48H	●	●	25×25	150	26	3	17	48-66			
	2020R/L7-60H	○	○	20×20	150	21	3	7	60-80			
	2020R/L10-60H	○	○	20×20	150	21	3	10	60-80			
	2525R/L10-60H	●	●	25×25	150	26	3	10	60-80			
	2525R/L17-60H	●	●	25×25	150	26	3	17	60-80			
	2020R/L7-74H	○	○	20×20	150	21	3	7	74-110			
	2020R/L10-74H	○	○	20×20	150	21	3	10	74-110			
	2525R/L10-74H	●	●	25×25	150	26	3	10	74-110			
	2525R/L17-74H	●	●	25×25	150	26	3	17	74-110			
	2020R/L7-100H	○	○	20×20	150	21	3	7	100-150			
	2020R/L10-100H	○	○	20×20	150	21	3	10	100-150			
2525R/L10-100H	●	●	25×25	150	26	3	10	100-150				
2525R/L17-100H	●	●	25×25	150	26	3	17	100-150				
QFGD	2020R/L10-52H	○	○	20×20	150	21	4	10	52-72	ZTGD0404-MG	GB70-85-M6×20	WH50L
	2525R/L13-52H	●	●	25×25	150	26	4	13	52-72			
	2020R/L15-52H	○	○	20×20	150	21	4	15	52-72			
	2525R/L22-52H	●	●	25×25	150	26	4	22	52-72			
	2020R/L10-64H	○	○	20×20	150	21	4	10	64-100			
	2525R/L13-64H	●	●	25×25	150	26	4	13	64-100			
	2020R/L15-64H	○	○	20×20	150	21	4	15	64-100			
	2525R/L22-64H	●	●	25×25	150	26	4	22	64-100			
	2020R/L10-90H	○	○	20×20	150	21	4	10	90-140			
	2525R/L13-90H	●	●	25×25	150	26	4	13	90-140			
	2020R/L15-90H	○	○	20×20	150	21	4	15	90-140			
	2525R/L22-90H	●	●	25×25	150	26	4	22	90-140			
	2020R/L10-130H	○	○	20×20	150	21	4	10	130-230			
	2525R/L13-130H	●	●	25×25	150	26	4	13	130-230			
2020R/L15-130H	○	○	20×20	150	21	4	15	130-230				
2525R/L22-130H	●	●	25×25	150	26	4	22	130-230				

● ex stock · ab Lager ○ on demand · auf Anfrage

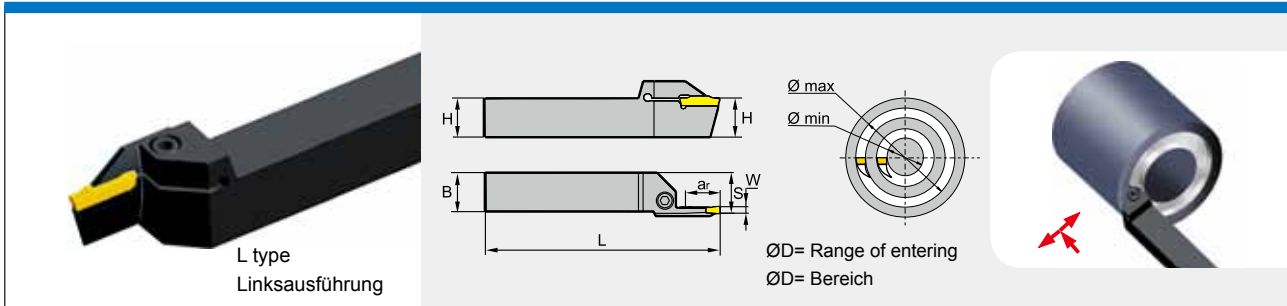
■ Axial grooving and turning tools · Axialstech- & Drehwerkzeug



Type · Typ		Stock		Dimension (mm) Abmessung						Inserts Stechplatten	Screw Schraube	Wrench Schlüssel
		R	L	H×B	L	S	W	ar _{max}	ØD (min-max)			
QFHD	2525R/L13-58H	●	●	25×25	150	26	5	13	58-96	ZTHD0504-MG	GB70-85-M6×20	WH50L
	2525R/L22-58H	●	●	25×25	150	26	5	22	58-96			
	2525R/L13-86H	●	●	25×25	150	26	5	13	86-140			
	2525R/L22-86H	●	●	25×25	150	26	5	22	86-140			
	2525R/L13-130H	●	●	25×25	150	26	5	13	130-200			
	2525R/L22-130H	●	●	25×25	150	26	5	22	130-200			
	2525R/L13-185H	●	●	25×25	150	26	5	13	185-400			
2525R/L22-185H	●	●	25×25	150	26	5	22	185-400				
QFHS	2525R/L30-185H	●	●	25×25	150	26	5	30	185-400	ZTHS0504-MG		
QFKD	2525R/L13-60H	●	●	25×25	150	26	6	13	60-100	ZTKD0608-MG	GB70-85-M6×20	WH50L
	2525R/L22-60H	●	●	25×25	150	26	6	22	60-100			
	2525R/L13-88H	○	●	25×25	150	26	6	13	88-180			
	2525R/L22-88H	●	●	25×25	150	26	6	22	88-180			
	2525R/L13-160H	●	●	25×25	150	26	6	13	160-400			
2525R/L22-160H	●	●	25×25	150	26	6	22	160-400				
QFKS	2525R/L30-160H	●	●	25×25	150	26	6	30	160-400	ZTKS0608-MG		



● ex stock · ab Lager ○ on demand · auf Anfrage

Turning · Drehen

Parting & Grooving · Ab- & Einstechen

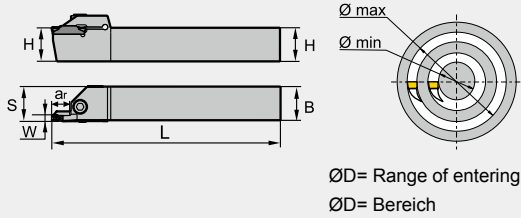
■ Axial grooving and turning tools · Axialstech- & Drehwerkzeug



Type · Typ		Stock		Dimension (mm) Abmessung						Inserts Stechplatten	Screw Schraube	Wrench Schlüssel
		R	L	H×B	L	S	W	ar max	ØD (min-max)			
QFFD	2020RR7-48H	○	○	20×20	150	21	3	7	48-66	ZTFD0303-MG	GB70-85-M6×20	WH50L
	2020RR10-48H	○	○	20×20	150	21	3	10	48-66			
	2525RR10-48H	○	○	25×25	150	26	3	10	48-66			
	2525RR17-48H	○	○	25×25	150	26	3	17	48-66			
	2020RR7-60H	○	○	20×20	150	21	3	7	60-80			
	2020RR10-60H	○	○	20×20	150	21	3	10	60-80			
	2525RR10-60H	○	○	25×25	150	26	3	10	60-80			
	2525RR17-60H	○	○	25×25	150	26	3	17	60-80			
	2020RR7-74H	○	○	20×20	150	21	3	7	74-110			
	2020RR10-74H	○	○	20×20	150	21	3	10	74-110			
	2525RR10-74H	○	○	25×25	150	26	3	10	74-110			
	2525RR17-74H	○	○	25×25	150	26	3	17	74-110			
	2020RR7-100H	○	○	20×20	150	21	3	7	100-150			
	2020RR10-100H	○	○	20×20	150	21	3	10	100-150			
2525RR10-100H	○	○	25×25	150	26	3	10	100-150				
2525RR17-100H	○	○	25×25	150	26	3	17	100-150				
QFGD	2020RR10-52H	○	○	20×20	150	21	4	10	52-72	ZTGD0404-MG	GB70-85-M6×20	WH50L
	2020RR15-52H	○	○	20×20	150	26	4	15	52-72			
	2525RR13-52H	○	○	25×25	150	21	4	13	52-72			
	2525RR22-52H	○	○	25×25	150	26	4	22	52-72			
	2020RR10-64H	○	○	20×20	150	21	4	10	64-100			
	2020RR15-64H	○	○	20×20	150	26	4	15	64-100			
	2525RR13-64H	○	○	25×25	150	21	4	13	64-100			
	2525RR22-64H	○	○	25×25	150	26	4	22	64-100			
	2020RR10-90H	○	○	20×20	150	21	4	10	90-140			
	2020RR15-90H	○	○	20×20	150	26	4	15	90-140			
	2525RR13-90H	○	○	25×25	150	21	4	13	90-140			
	2525RR22-90H	○	○	25×25	150	26	4	22	90-140			
	2020RR10-130H	○	○	20×20	150	21	4	10	130-230			
	2020RR15-130H	○	○	20×20	150	26	4	15	130-230			
2525RR13-130H	○	○	25×25	150	21	4	13	130-230				
2525RR22-130H	○	○	25×25	150	26	4	22	130-230				

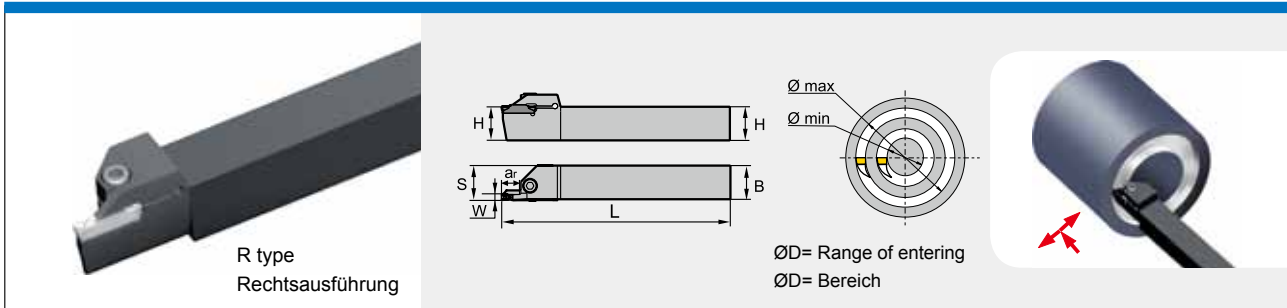

● ex stock · ab Lager ○ on demand · auf Anfrage

■ Axial grooving and turning tools · Axialstech- & Drehwerkzeug



R type
Rechtsausführung

ØD= Range of entering
ØD= Bereich

Type · Typ		Stock		Dimension (mm) Abmessung						Inserts Stechplatten	Screw Schraube	Wrench Schlüssel
		R	L	H×B	L	S	W	ar max	ØD (min-max)			
QFHD	2525RR13-58H	○	○	25×25	150	26	5	13	58-96	ZTHD0504-MG	GB70-85-M6×20	WH50L
	2525RR22-58H	○	○	25×25	150	26	5	22	58-96			
	2525RR13-86H	○	○	25×25	150	26	5	13	86-140			
	2525RR22-86H	○	○	25×25	150	26	5	22	86-140			
	2525RR13-130H	○	○	25×25	150	26	5	13	130-200			
	2525RR22-130H	○	○	25×25	150	26	5	22	130-200			
	2525RR13-185H	○	○	25×25	150	26	5	13	185-400			
	2525RR22-185H	○	○	25×25	150	26	5	22	185-400			
QFHS	2525RR30-185H	○	○	25×25	150	26	5	30	185-400	ZTHS0504-MG		
QFKD	2525RR13-60H	○	○	25×25	150	26	6	13	60-100	ZTKD0608-MG	GB70-85-M6×20	WH50L
	2525RR22-60H	○	○	25×25	150	26	6	22	60-100			
	2525RR13-88H	○	○	25×25	150	26	6	13	88-180			
	2525RR22-88H	○	○	25×25	150	26	6	22	88-180			
	2525RR13-160H	○	○	25×25	150	26	6	13	160-400			
2525RR22-160H	○	○	25×25	150	26	6	22	160-400				
QFKS	2525RR30-160H	○	○	25×25	150	26	6	30	160-400	ZTKS0608-MG		

● ex stock · ab Lager ○ on demand · auf Anfrage

Turning · Drehen

Parting & Grooving · Ab- & Einstechen

■ Axial grooving and turning tools · Axialstech- & Drehwerkzeug



L type
Linksausführung

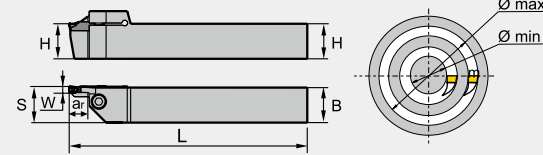

ØD= Range of entering
ØD= Bereich



Type · Typ		Stock		Dimension (mm) Abmessung						Inserts Stechplatten	Screw Schraube	Wrench Schlüssel
		R	L	H×B	L	S	W	ar max	ØD (min-max)			
QFFD	2020LL7-48H	○	○	20×20	150	21	3	7	48-66	ZTFD0303-MG	GB70-85-M6×20	WH50L
	2020LL10-48H	○	○	20×20	150	21	3	10	48-66			
	2525LL10-48H	○	○	25×25	150	26	3	10	48-66			
	2525LL17-48H	○	○	25×25	150	26	3	17	48-66			
	2020LL7-60H	○	○	20×20	150	21	3	7	60-80			
	2020LL10-60H	○	○	20×20	150	21	3	10	60-80			
	2525LL10-60H	○	○	25×25	150	26	3	10	60-80			
	2525LL17-60H	○	○	25×25	150	26	3	17	60-80			
	2020LL7-74H	○	○	20×20	150	21	3	7	74-110			
	2020LL10-74H	○	○	20×20	150	21	3	10	74-110			
	2525LL10-74H	○	○	25×25	150	26	3	10	74-110			
	2525LL17-74H	○	○	25×25	150	26	3	17	74-110			
	2020LL7-100H	○	○	20×20	150	21	3	7	100-150			
	2020LL10-100H	○	○	20×20	150	21	3	10	100-150			
	2525LL10-100H	○	○	25×25	150	26	3	10	100-150			
2525LL17-100H	○	○	25×25	150	26	3	17	100-150				
QFGD	2020LL10-52H	○	○	20×20	150	21	4	10	52-72	ZTGD0404-MG	GB70-85-M6×20	WH50L
	2020LL15-52H	○	○	20×20	150	26	4	15	52-72			
	2525LL13-52H	○	○	25×25	150	21	4	13	52-72			
	2525LL22-52H	○	○	25×25	150	26	4	22	52-72			
	2020LL10-64H	○	○	20×20	150	21	4	10	64-100			
	2020LL15-64H	○	○	20×20	150	26	4	15	64-100			
	2525LL13-64H	○	○	25×25	150	21	4	13	64-100			
	2525LL22-64H	○	○	25×25	150	26	4	22	64-100			
	2020LL10-90H	○	○	20×20	150	21	4	10	90-140			
	2020LL15-90H	○	○	20×20	150	26	4	15	90-140			
	2525LL13-90H	○	○	25×25	150	21	4	13	90-140			
	2525LL22-90H	○	○	25×25	150	26	4	22	90-140			
	2020LL10-130H	○	○	20×20	150	21	4	10	130-230			
	2020LL15-130H	○	○	20×20	150	26	4	15	130-230			
	2525LL13-130H	○	○	25×25	150	21	4	13	130-230			
2525LL22-130H	○	○	25×25	150	26	4	22	130-230				

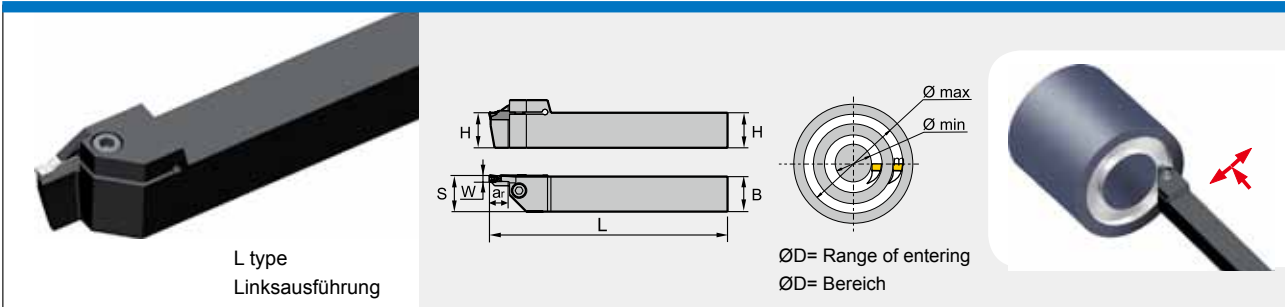

● ex stock · ab Lager ○ on demand · auf Anfrage

■ Axial grooving and turning tools · Axialstech- & Drehwerkzeug



L type
Linksausführung

ØD= Range of entering
ØD= Bereich

Type · Typ		Stock		Dimension (mm) Abmessung						Inserts Stechplatten	Screw Schraube	Wrench Schlüssel
		R	L	H×B	L	S	W	a _r max	ØD (min-max)			
QFHD	2525LL13-58H	○	○	25×25	150	26	5	13	58-96	ZTHD0504-MG	GB70-85-M6×20	WH50L
	2525LL22-58H	○	○	25×25	150	26	5	22	58-96			
	2525LL13-86H	○	○	25×25	150	26	5	13	86-140			
	2525LL22-86H	○	○	25×25	150	26	5	22	86-140			
	2525LL13-130H	○	○	25×25	150	26	5	13	130-200			
	2525LL22-130H	○	○	25×25	150	26	5	22	130-200			
	2525LL13-185H	○	○	25×25	150	26	5	13	185-400			
	2525LL22-185H	○	○	25×25	150	26	5	22	185-400			
QFHS	2525LL30-185H	○	○	25×25	150	26	5	30	185-400	ZTHS0504-MG		
QFKD	2525LL13-60H	○	○	25×25	150	26	6	13	60-100	ZTKD0608-MG	GB70-85-M6×20	WH50L
	2525LL22-60H	○	○	25×25	150	26	6	22	60-100			
	2525LL13-88H	○	○	25×25	150	26	6	13	88-180			
	2525LL22-88H	○	○	25×25	150	26	6	22	88-180			
	2525LL13-160H	○	○	25×25	150	26	6	13	160-400			
	2525LL22-160H	○	○	25×25	150	26	6	22	160-400			
QFKS	2525LL30-160H	○	○	25×25	150	26	6	30	160-400	ZTKS0608-MG		

● ex stock · ab Lager ○ on demand · auf Anfrage

Turning · Drehen

Parting & Grooving · Ab- & Einstechen

L type tools for Axial grooving and turning · L Typ Axialstech- & Drehwerkzeug

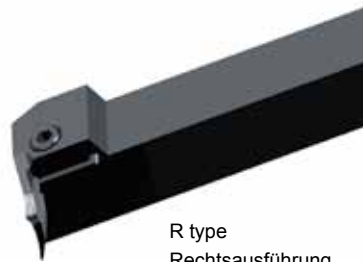

R type
Rechtsausführung

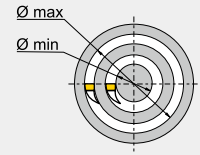
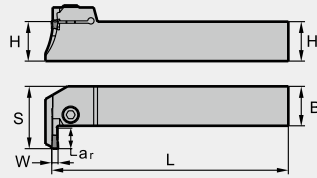

ØD= Range of entering
ØD= Bereich



Type · Typ		Stock		Dimension (mm) Abmessung					Inserts Wendeschneidplatten	Screw Schraube	Wrench Schlüssel	
		R	L	H×B	L	S	W	ar max	ØD (min-max)			
QFFD	2020R/L7-48L	○	○	20×20	150	28.5	3	7	48-66	ZTFD0303-MG	GB70-85-M6×20	WH50L
	2020R/L10-48L	○	○	20×20	150	31.5	3	10	48-66			
	2525R/L10-48L	○	○	25×25	150	36.5	3	10	48-66			
	2525R/L17-48L	○	○	25×25	150	43.5	3	17	48-66			
	2020R/L7-60L	○	○	20×20	150	28.5	3	7	60-80			
	2020R/L10-60L	○	○	20×20	150	31.5	3	10	60-80			
	2525R/L10-60L	○	○	25×25	150	36.5	3	10	60-80			
	2525R/L17-60L	○	○	25×25	150	43.5	3	17	60-80			
	2020R/L7-74L	○	○	20×20	150	28.5	3	7	74-110			
	2020R/L10-74L	○	○	20×20	150	31.5	3	10	74-110			
	2525R/L10-74L	○	○	25×25	150	36.5	3	10	74-110			
	2525R/L17-74L	○	○	25×25	150	43.5	3	17	74-110			
	2020R/L7-100L	○	○	20×20	150	28.5	3	7	100-150			
	2020R/L10-100L	○	○	20×20	150	31.5	3	10	100-150			
2525R/L10-100L	○	○	25×25	150	36.5	3	10	100-150				
2525R/L17-100L	○	○	25×25	150	43.5	3	17	100-150				
QFGD	2020R/L10-52L	○	○	20×20	150	31.5	4	10	52-72	ZTGD0404-MG	GB70-85-M6×20	WH50L
	2525R/L13-52L	○	○	25×25	150	39.5	4	13	52-72			
	2020R/L15-52L	○	○	20×20	150	36.5	4	15	52-72			
	2525R/L22-52L	○	○	25×25	150	48.5	4	22	52-72			
	2020R/L10-64L	○	○	20×20	150	31.5	4	10	64-100			
	2525R/L13-64L	○	○	25×25	150	39.5	4	13	64-100			
	2020R/L15-64L	○	○	20×20	150	36.5	4	15	64-100			
	2525R/L22-64L	○	○	25×25	150	48.5	4	22	64-100			
	2020R/L10-90L	○	○	20×20	150	31.5	4	10	90-140			
	2525R/L13-90L	○	○	25×25	150	39.5	4	13	90-140			
	2020R/L15-90L	○	○	20×20	150	36.5	4	15	90-140			
	2525R/L22-90L	○	○	25×25	150	48.5	4	22	90-140			
	2020R/L10-130L	○	○	20×20	150	31.5	4	10	130-230			
	2525R/L13-130L	○	○	25×25	150	39.5	4	13	130-230			
2020R/L15-130L	○	○	20×20	150	36.5	4	15	130-230				
2525R/L22-130L	○	○	25×25	150	48.5	4	22	130-230				

● ex stock · ab Lager ○ on demand · auf Anfrage

L type tools for Axial grooving and turning · L Typ Axialstech- & Drehwerkzeug

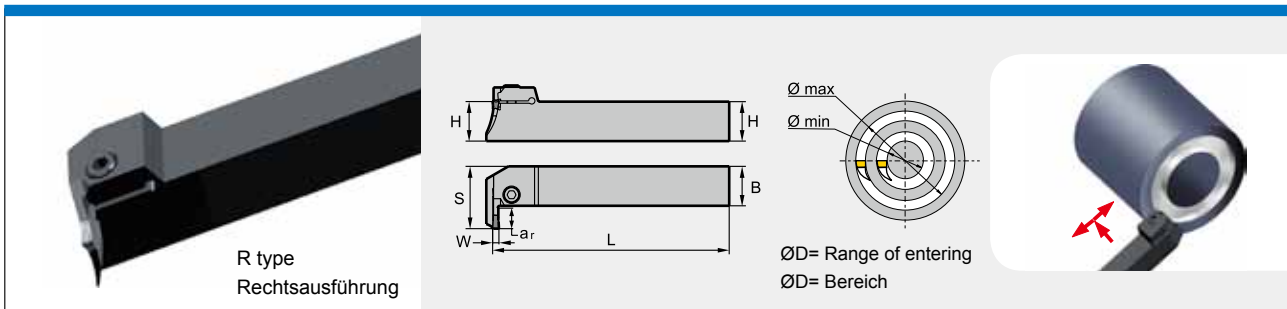

Type · Typ		Stock		Dimension (mm) Abmessung						Inserts Stechplatten	Screw Schraube	Wrench Schlüssel
		R	L	H×B	L	S	W	ar max	ØD (min-max)			
QFHD	2525R/L13-58L	○	○	25×25	150	39.5	5	13	58-96	ZTHD0504-MG	GB70-85-M6×20	WH50L
	2525R/L22-58L	○	○	25×25	150	48.5	5	22	58-96			
	2525R/L13-86L	○	○	25×25	150	39.5	5	13	86-140			
	2525R/L22-86L	○	○	25×25	150	48.5	5	22	86-140			
	2525R/L13-130L	○	○	25×25	150	39.5	5	13	130-200			
	2525R/L22-130L	○	○	25×25	150	48.5	5	22	130-200			
	2525R/L13-185L	○	○	25×25	150	39.5	5	13	185-400			
QFHS	2525R/L22-185L	○	○	25×25	150	48.5	5	22	185-400	ZTHS0504-MG		
QFKD	2525R/L13-60L	○	○	25×25	150	39.5	6	13	60-100	ZTKD0608-MG	GB70-85-M6×20	WH50L
	2525R/L22-60L	○	○	25×25	150	48.5	6	22	60-100			
	2525R/L13-88L	○	○	25×25	150	39.5	6	13	88-180			
	2525R/L22-88L	○	○	25×25	150	48.5	6	22	88-180			

● ex stock · ab Lager ○ on demand · auf Anfrage

Turning · Drehen

Parting & Grooving · Ab- & Einstechen

Internal grooving and turning tools · Einstech- & Drehwerkzeuge (Innen)

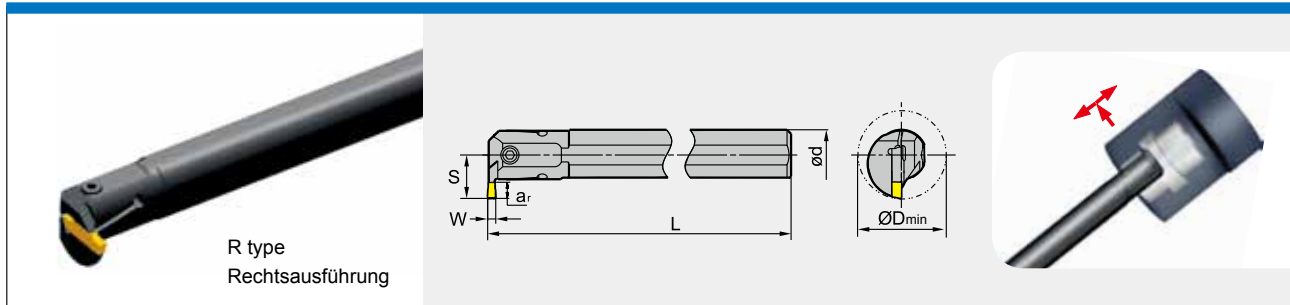

Type · Typ	Stock		Dimension (mm) Abmessung						Inserts Stechplatte	Screw Schraube	Wrench Schlüssel
	R	L	ød	L	S	W	ar _{max}	ØD _{min}			
C20Q-QEDR/L05-27	●	○	20	180	15.2	2.5	5	27	ZTED02* ZRED025*	GB70-85-M4×12	WH30L
C25R-QEDR/L07-33	●	●	25	200	20.3	2.5	7	33		GB70-85-M5×16	WH40L
C32S-QEDR/L09-42	●	●	32	250	25.3	2.5	9	42		GB70-85-M5×20	
C20Q-QFDR/L05-27	●	●	20	0	15.2	3	5	27	ZTFD03* ZRFD03*	GB70-85-M4×12	WH30L
C25R-QFDR/L07-33	●	●	25	200	20.3	3	7	33		GB70-85-M5×16	WH40L
C32S-QFDR/L09-42	●	●	32	250	25.3	3	9	42		GB70-85-M5×20	
C25R-QGDR/L08-35	●	●	25	200	21.5	4	8	35	ZTGD04* ZRGD04*	GB70-85-M5×16	WH40L
C32S-QGDR/L11-44	●	●	32	250	27.5	4	11	44		GB70-85-M6×20	WH50L
C40T-QGDR/L13-54	●	●	40	300	33.5	4	13	54		GB70-85-M6×20	
C25R-QHDR/L08-35	○	○	25	200	21.5	5	8	35	ZTHD05* ZRH05*	GB70-85-M5×16	WH40L
C32S-QHDR/L11-44	●	●	32	250	27.5	5	11	44		GB70-85-M6×20	WH50L
C40T-QHDR/L13-54	●	○	40	300	33.5	5	13	54		GB70-85-M6×20	
C25R-QKDR/L08-35	○	○	25	200	21.5	6	8	35	ZTKD06* ZRKD06*	GB70-85-M5×16	WH40L
C32S-QKDR/L11-44	●	●	32	250	27.5	6	11	44		GB70-85-M6×20	WH50L
C40T-QKDR/L13-54	●	●	40	300	33.5	6	13	54		GB70-85-M6×20	

Profiling and turning tools for Al · Profildreh- & Einstechwerkzeuge für Alu (Innen)

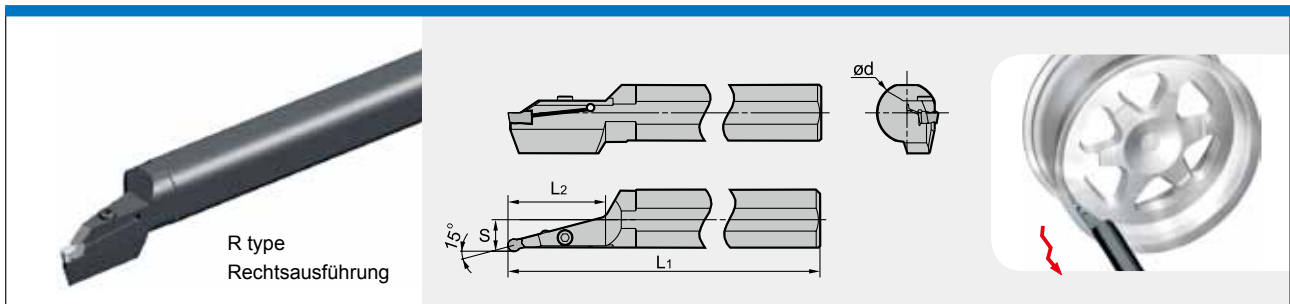

Type · Typ	Stock		Dimension (mm) Abmessung					Inserts Stechplatten	Screw Schraube	Wrench Schlüssel
	R	L	ØD ₀	ød	S	L ₁	L ₂			
C40X-QLDR/L65-15A	●	●	160	40	21	320	65	ZRLD08-LH	GB70-85-M6×20	WH50L
C40X-QLDR/L80-15A	●	○	160	40	21	320	80	ZRLD08-LH		
C40X-QKDR/L60-15A	○	○	160	40	20	320	60	ZRKD06-LH		
C40X-QKDR/L75-15A	○	○	160	40	20	320	75	ZRKD06-LH		

● ex stock · ab Lager ○ on demand · auf Anfrage

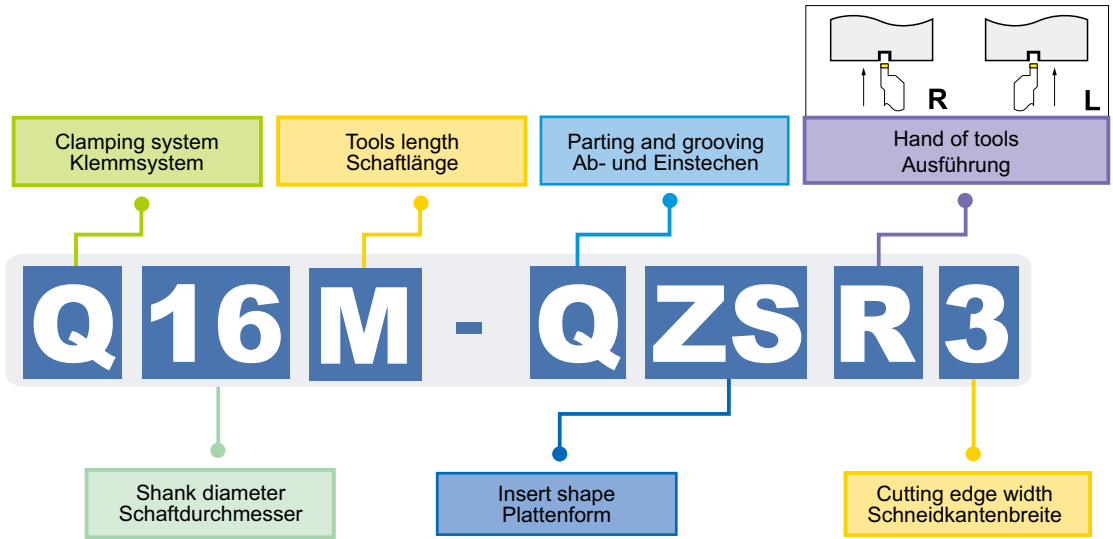
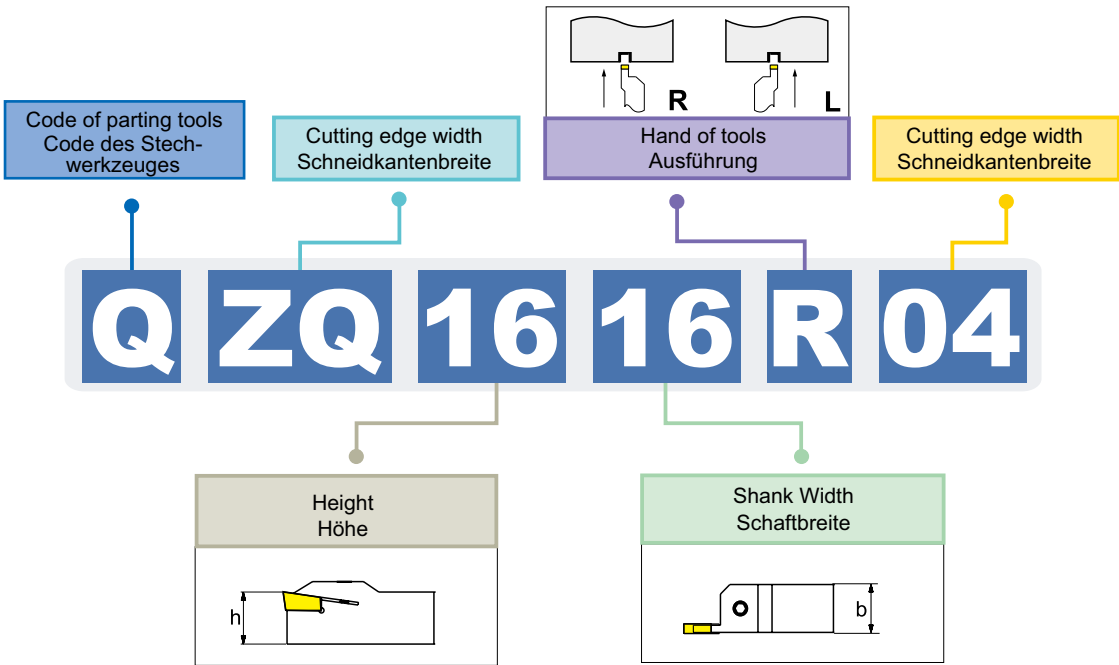



Turning · Drehen

Parting & Grooving · Ab- & Einstechen

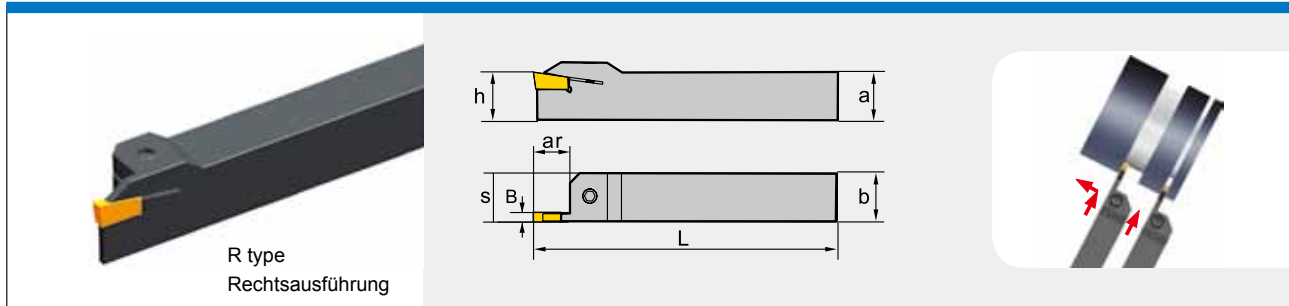
External parting and grooving · Ab- & Einstechwerkzeug (Außen): QZQ Series



Type · Typ		Stock		Dimension (mm) Abmessung						Inserts Stechplatten	Screw Schraube	Wrench Schlüssel
		R	L	a=h	b	L	S	B	a _{r max}			
QZQ	1616R/L03	●	●	16	16	100	16.4	3	16	ZQMX3N11-IE	GB70-85-M5×16	WH40L
	1616R/L04	○	○	16	16	100	16.4	4	18	ZQMX4N11-IE		
	2020R/L03	●	●	20	20	125	20.4	3	20	ZQMX3N11-IE		
	2020R/L04	●	●	20	20	125	20.4	4	20	ZQMX4N11-IE		
	2525R/L03	●	●	25	25	150	25.4	3	20	ZQMX3N11-IE	GB70-85-M6×20	WH50L
	2525R/L04	●	●	25	25	150	25.4	4	20	ZQMX4N11-IE		
	2525R/L05	●	●	25	25	150	25.4	5	25	ZQMX5N11-IE		
	2525R/L06	●	●	25	25	150	25.7	6	32	ZQMX6N11-IE		
	3225R/L03	●	○	32	25	170	25.4	3	25	ZQMX3N11-IE		
	3225R/L04	●	○	32	25	170	25.4	4	25	ZQMX4N11-IE		
	3225R/L05	●	○	32	25	170	25.4	5	25	ZQMX5N11-IE		
	3225R/L06	●	●	32	25	170	25.7	6	35	ZQMX6N11-IE		

● ex stock · ab Lager ○ on demand · auf Anfrage

Internal parting and grooving · Ab- & Einstechwerkzeug (Innen): QZS Series

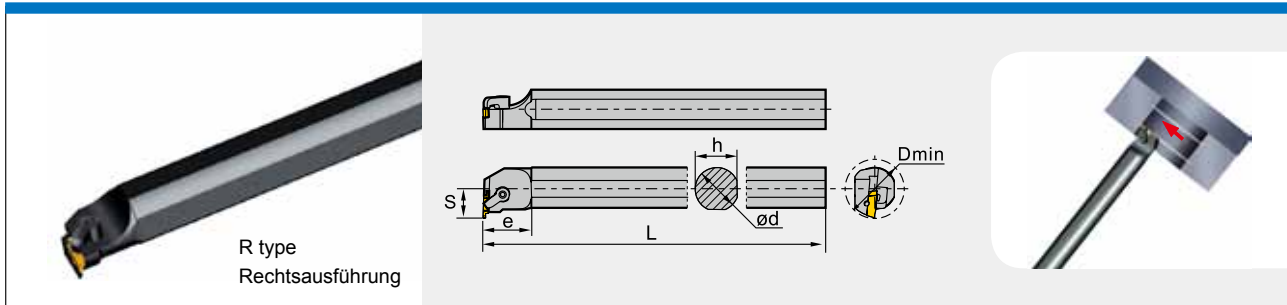

R type
Rechtausführung

Type · Typ	Stock		Dimension (mm) Abmessung						Inserts Stechplatten	Screw Schraube	Wrench Schlüssel	Clamp Klemme
	R	L	L	h	S	e	ØD	ød				
C16M-QZSR3	○		150	15	11	17	20	16	ZS**3**L	DM5x14	WH25L	C4RD
C20M-QZSR3	○		150	18	13.5	22	26	20				
C25R-QZSR3	○		200	23	17	22	32	25				
C40T-QZSR3	○		300	37	27	32	50	40	ZSM*5**L			
C25R-QZSR5	○		200	23	17	2	20	25				
C40T-QZSR5	○		300	37	27	32	50	40				
C16M-QZSL3		○	10	15	11	17	32	16	ZSM*3*R			
C20M-QZSL3		○	150	18	13.5	22	26	20				
C25R-QZSL3		○	200	23	17	22	32	25				
C40T-QZSL3		○	300	37	27	32	50	40	ZSM*5*R			
C25R-QZSL5		○	200	23	17	22	32	25				
C40T-QZSL5		○	300	37	27	32	50	40				

External parting and grooving · Ab- & Einstechwerkzeug (Außen) : QZS Series

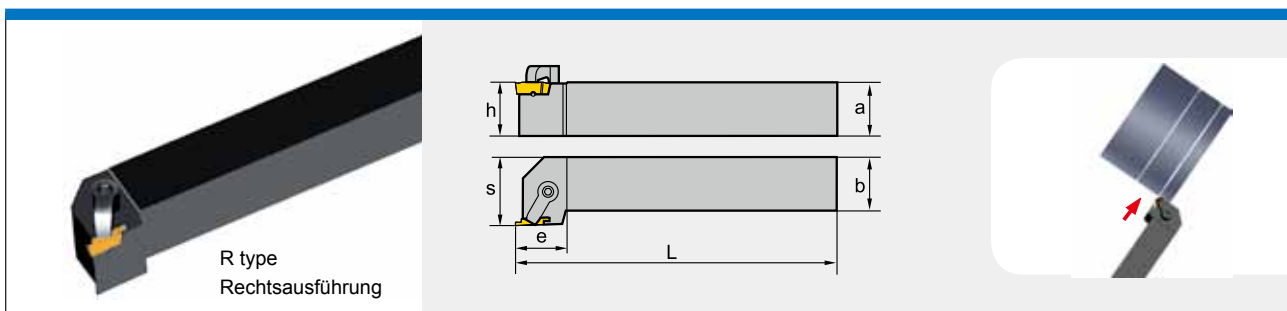

R type
Rechtausführung

Type · Typ	Stock		Dimension (mm) Abmessung						Inserts Stechplatten	Screw Schraube	Wrench Schlüssel	Clamp Klemme
	R	L	a	b	L	h	s	e				
QZS2525R3	○		25	25	150	25	32	23.5	ZS**3***R	DM6x25	WH30L	C2RD
QZS2525R5	○		25	25	150	25	32	23.5	ZSM*5***R			
QZS2525L3		○	25	25	150	25	32	23.5	ZSM*3***L			
QZS2525L5		○	25	25	150	25	32	23.5	ZSM*5***L			





● ex stock · ab Lager ○ on demand · auf Anfrage

Turning · Drehen

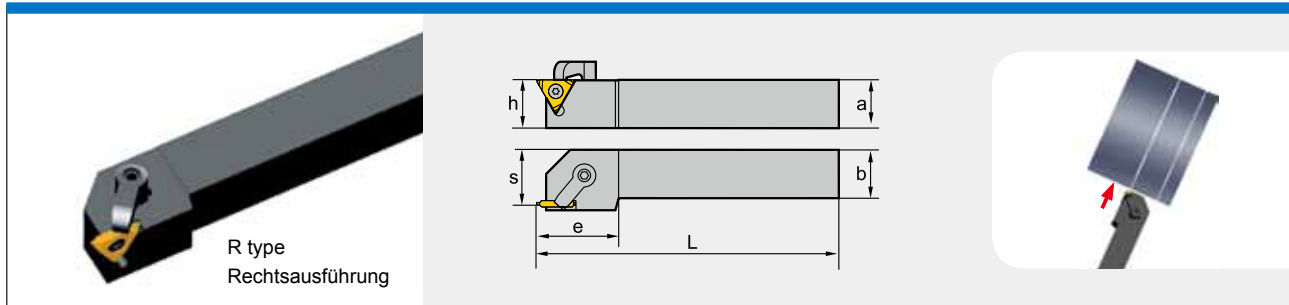
Parting & Grooving · Ab- & Einstechen

External parting and grooving · Ab- & Einstechwerkzeug (Außen) : QT Series



Type · Typ	Stock		Dimension (mm) Abmessung					Inserts Stechplatten	Screw Schraube	Screw Schraube	Wrench Schlüssel	Clamp Klemme
	R	L	a	b	L	h	s					
QT2020R/L3	●		20	20	125	20	22	154.3-161	I90M3.5x8	DM6x25	WT09IP WH30L	C2RD
QT2020R/L4	●		20	20	125	20	21	154.3-163				
QT2525R/L3	●		25	25	150	25	27	154.3-162				
QT2525R/L4	●		25	25	150	25	26	154.3-164				

● ex stock · ab Lager ○ on demand · auf Anfrage

Center height controlling of parting and grooving tools Einstellung der Schneidhöhe beim Ab- & Einstechen

- No matter what kind of parting and grooving cutting tools you choose, you should keep 90° between the insert and the center line of the work-piece material to get perfect machined surface, and to reduce liberation during machining.
 - Bitte montieren Sie den Werkzeughalter so, dass er im 90° Winkel zur Mittelachse des Werkstücks steht. Dadurch erhalten Sie eine bessere Oberflächengüte und verringern das Risiko von Schwingungen.
 - Height tolerance between the cutting edge of an insert and the center of work piece should be kept $\pm 0.1\text{mm}$, especially for the parting of rods and grooving of materials with a small diameter. You achieve a longer tool lifetime and reduce cutting resistance and burrs.
 - Bitte montieren Sie Ihren Werkzeughalter so, dass er beim Abstechen oder Einstechen speziell bei Werkstücken mit kleineren Durchmessern im Toleranzbereich von $\pm 0.1\text{ mm}$ zur Mittelachse steht. Sie erreichen dadurch eine längere Standzeit, reduzieren die Schnittkräfte und Butzenbildung.
- ### Parting · Abstechen
- A reduction of the feedrate by 30% is preferred when the inserts approach the centre of workpiece, prolonging the life-time of the inserts.
 - Eine Reduzierung des Vorschubs um 30% bei der Annäherung der Schneide an die Mittelachse des Werkstücks verlängert die Standzeit der Stechplatte.
 - A tool holder overhang with as little as possible to insure good stability.
 - Werkzeughalter mit kleinstmöglichem Überhang wählen, um Vibrationen und Werkzeugablenkung zu vermeiden.

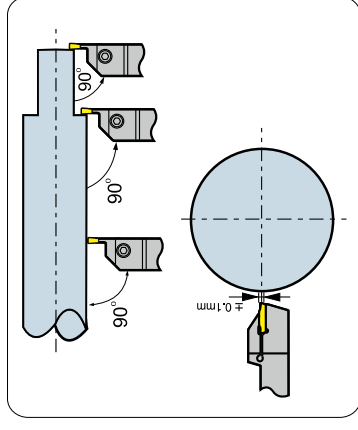

External grooving, turning and profile turning · Längsdrehen, Profildrehen

- Cutting sequences: As the cutting depth is bigger than 0.5mm, radial cutting (biggest cutting depth 0.75 x edge width of insert) radial backing 0.1mm axial feed oblique back axial cutting radial cutting to the depth require.
- Bearbeitungsfolge 0,5mm: Radialer Vorschub auf erforderliche Schnitttiefe (ap max. 0.75 x Schneidplattenbreite) radiales Zurücksetzen um 0.1 mm Längsdrehen zur gegenüberliegenden Schulter diagonales Zurücksetzen um 0.5mm nach außen axial Vorschub bis zum Startpunkt radialer Vorschub auf erforderliche Schnitttiefe usw.
- When cutting bottom border or chamfering, do what the sketch show, reducing liberation by the friction of cutting tools with chippings.
- Beim Drehen des Nutgrundes oder der Fase befolgen Sie die nebenstehenden Arbeitsschritte. Dies reduziert die Auslenkung des Werkzeuges und verhindert Schneidkantenausbrüche.

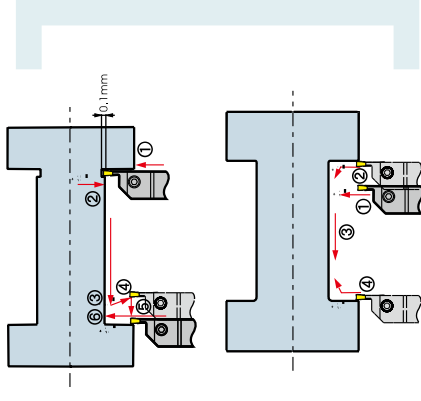

Surface grooving and turning · Axialeinstechen

Roughing · Schruppen

- Infeed from largest \varnothing inwards insert offset slightly from inner side of groove when retracting as shown in sketch (1).
- Bearbeitung vom größten \varnothing zur Achse hin. Beim Zurückfahren des Werkzeuges empfiehlt es sich, diese leicht abzuwinkeln.

Flute turning · Nutdrehen

- Depth of axial turning less than 0.75 x S (Width of insert)
width > depth of breaker, suggest to do as shown in sketch (2)
depth > width of breaker, suggest to cut with a lot breaker.
- Spantiefe bei axialem Vorschub kleiner als 0.75 x S (Breite des Schneideinsatzes)
Wenn die Kammerbreite größer ist als die Tiefe, folgen Sie den abgebildeten Arbeitsschritten. Wenn die Kammertiefe größer ist als die Breite, empfehlen wir in einzelnen Schritten auf den geforderten \varnothing zu stechen (2).

Finishing · Schlichten

- Finish machining external \varnothing and bottom firstly, then machining the internal \varnothing to the size required as shown in sketch (3).
- Zum Schlichten bearbeiten Sie zuerst den äußeren \varnothing und den Grund. Anschließend bearbeiten Sie den inneren \varnothing bis zur erforderlichen Größe Skizze (3).

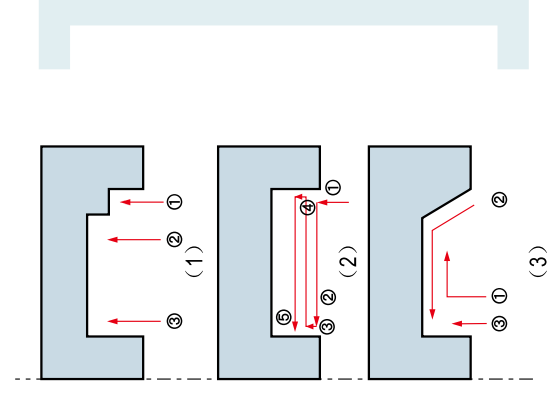

Internal grooving · Innenbearbeitung

• Follow the machining sequence as shown in the picture.
Good for chip flow, always feed along the direction of moving from the deepest in the hole to outside.

• Bearbeitungsfolge gemäß Skizze. Bei der Bearbeitung von Sackbohrungen, sollte zur besseren Spanabfuhr von innen nach außen gearbeitet werden.

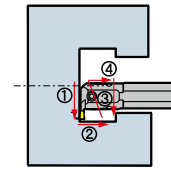

Recommended cutting parameters · Empfohlene Schnittparameter

Inserts Size Stechplatte Größe	Recommended feed rate (mm/rev) · Empfohlener Vorschub (mm/U)			
Inserts width(mm) Stechplatte Breite	Parting Abstechen	Grooving Einstechen	Turning Drehen	Profiling Profildrehen
2.5	0.05—0.15	0.05—0.15	0.05—0.15	0.05—0.15
3	0.05—0.15	0.05—0.15	0.07—0.15	0.1—0.2
4	0.05—0.2	0.05—0.2	0.07—0.25	0.1—0.2
5	0.07—0.2	0.07—0.22	0.1—0.25	0.15—0.3
6	0.1—0.3	0.07—0.25	0.1—0.3	0.15—0.3

Workpiece Material Werkstück Material		Hardness Härte	YBG302	YBG202	YBC151	YBC251	YD101	YD201	YBG102	YC10	YC40
P	Carbon steel Kohlenstoffstahl	125≤HB≤170	120-260	150-280	140-280	150-280				130-280	110-260
	Low alloy steel niedrig legierter Stahl	180≤HB≤275	80-175	110-200	100-240	110-200				90-200	70-175
	High alloy steel Hoch legierter Stahl	180≤HB≤325	80-160	110-190	100-220	110-190				90-190	70-160
	Cast steel Stahlguss	180≤HB≤250	75-140	100-170	80-160	100-170				80-170	60-140
M	Ferrite Martensite	200≤HB≤300	70-170	100-200		100-200				80-200	60-170
	Austenite	180≤HB≤300	80-200	110-220		110-220				90-220	70-200
K	Malleable cast iron Temperguss	130≤HB≤230	100-200	130-220				90-160			
	Grey cast iron Grauguss	180≤HB≤220	90-170	120-200				80-140			
	Nodular cast iron	160≤HB≤250	80-150	110-180				60-140			
N	Al alloy Alu-Legierung	--					200-400				
S	Heat resistant alloy hitzebeständigen Legierungen	≤400					20-50		30-60		

The cutting parameters recommended are suitable for wet machining.

Die angegebenen Schnittparameter werden für die Bearbeitung mit Kühlfüssigkeit empfohlen.

Advice: internal machining and Axial machining, The cutting speed should be reduced by 30%-40%.

Hinweis: Bei Innen- und Axialstechen, sollte die Schnittgeschwindigkeit um 30%-40% reduziert werden.