

### Indexable drill Code Key - ISO Kennzeichnung WSP- Bohrern

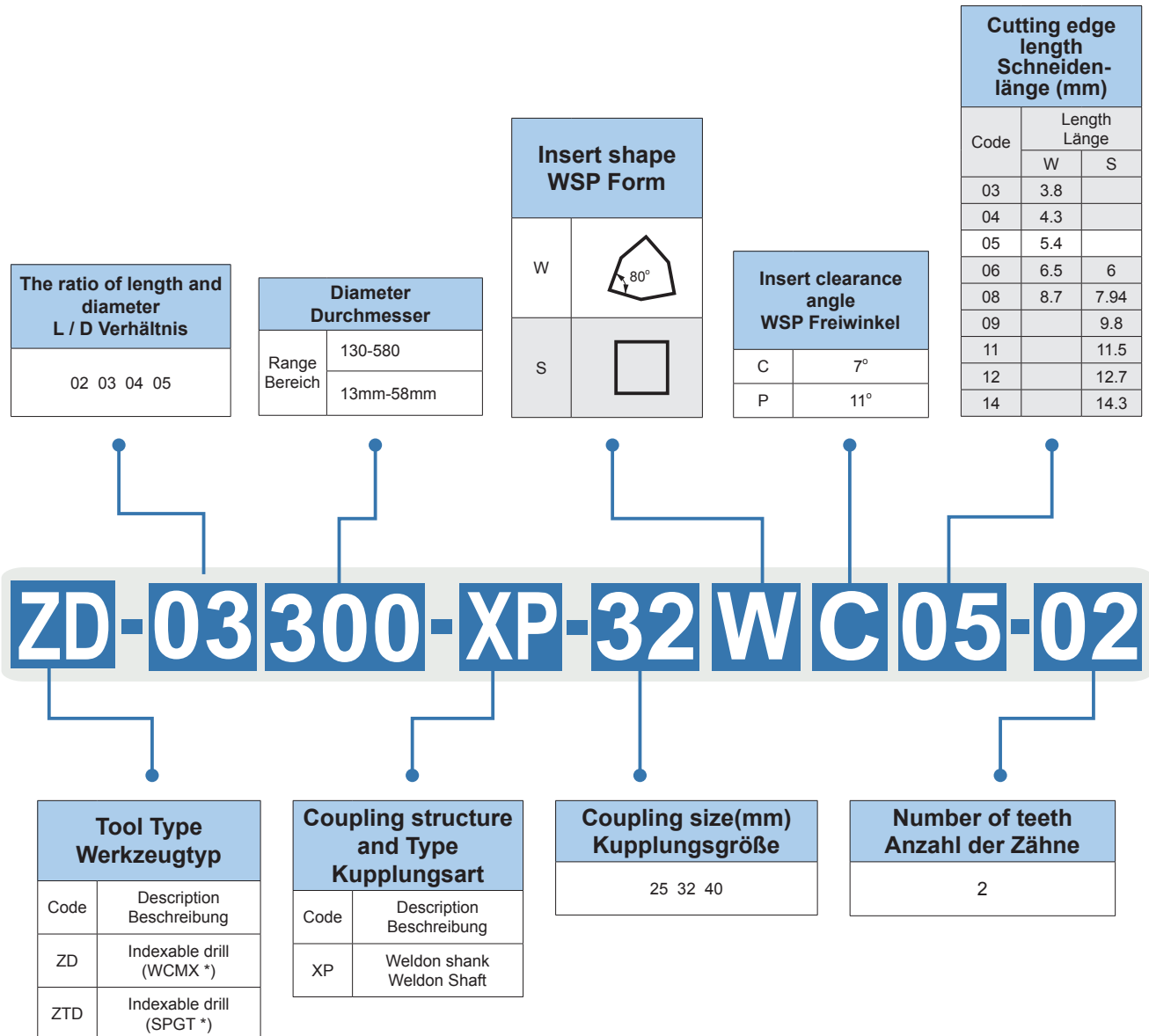

Indexable drills  
WPS-Bohrer

# Drilling · Bohren

Indexable drill · Wendeschneidplattenbohrer

## ZTD02

2D

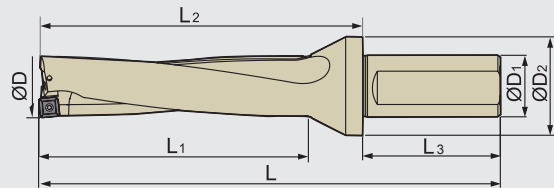
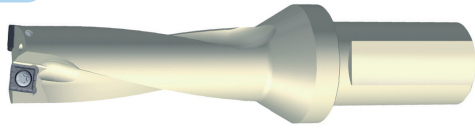

Type Typ	Stock Lager	Dimension Abmessung (mm)							Insert WSP	Screw Schraube	Wrench Schlüssel
		ØD	ØD1	ØD2	L3	L2	L1	L			
ZTD02-130-XP20-SP05-02	●	13	20	25	50	47	32	97	SPGT050204-PM/EM	160M2X4.3	WT06IP
ZTD02-140-XP20-SP05-02	●	14	20	25	50	49	34	99	SPGT050204-PM/EM	160M2X4.3	WT06IP
ZTD02-150-XP20-SP05-02	●	15	20	25	50	51	36	101	SPGT050204-PM/EM	160M2X4.3	WT06IP
ZTD02-160-XP20-SP05-02	●	16	20	25	50	53	38	103	SPGT050204-PM/EM	160M2X4.3	WT06IP
ZTD02-170-XP25-SP06-02	●	17	25	32	56	62	40	118	SPGT060204-PM/EM	160M2.2X5.5	WT07IP
ZTD02-180-XP25-SP06-02	●	18	25	32	56	64	42	120	SPGT060204-PM/EM	160M2.2X5.5	WT07IP
ZTD02-190-XP25-SP06-02	●	19	25	32	56	66	44	122	SPGT060204-PM/EM	160M2.2X5.5	WT07IP
ZTD02-200-XP25-SP06-02	●	20	25	32	56	68	46	124	SPGT060204-PM/EM	160M2.2X5.5	WT07IP
ZTD02-210-XP25-SP06-02	●	21	25	32	56	70	48	126	SPGT060204-PM/EM	160M2.2X5.5	WT07IP
ZTD02-220-XP25-SP07-02	●	22	25	32	56	72	50	128	SPGT07T308-PM/EM	160M2.5X6.5	WT07IP
ZTD02-230-XP25-SP07-02	●	23	25	32	56	74	52	130	SPGT07T308-PM/EM	160M2.5X6.5	WT07IP
ZTD02-240-XP25-SP07-02	●	24	25	32	56	76	54	132	SPGT07T308-PM/EM	160M2.5X6.5	WT07IP
ZTD02-250-XP25-SP07-02	●	25	25	32	56	78	56	134	SPGT07T308-PM/EM	160M2.5X6.5	WT07IP
ZTD02-260-XP25-SP07-02	●	26	25	32	56	80	58	136	SPGT07T308-PM/EM	160M2.5X6.5	WT07IP
ZTD02-270-XP25-SP07-02	●	27	25	32	56	82	60	138	SPGT07T308-PM/EM	160M2.5X6.5	WT07IP
ZTD02-280-XP32-SP09-02	●	28	32	37	60	87	62	147	SPGT090408-PM/EM	160M3.5X8	WT15IP
ZTD02-290-XP32-SP09-02	●	29	32	37	60	89	64	149	SPGT090408-PM/EM	160M3.5X8	WT15IP
ZTD02-300-XP32-SP09-02	●	30	32	37	60	91	66	151	SPGT090408-PM/EM	160M3.5X8	WT15IP
ZTD02-310-XP32-SP09-02	●	31	32	37	60	93	68	153	SPGT090408-PM/EM	160M3.5X8	WT15IP
ZTD02-320-XP32-SP09-02	●	32	32	37	60	95	70	155	SPGT090408-PM/EM	160M3.5X8	WT15IP
ZTD02-330-XP32-SP09-02	●	33	32	37	60	97	72	157	SPGT090408-PM/EM	160M3.5X8	WT15IP
ZTD02-340-XP40-SP11-02	●	34	40	47	70	104	74	174	SPGT110408-PM/EM	160M4X10	WT15IP
ZTD02-350-XP40-SP11-02	●	35	40	47	70	106	76	176	SPGT110408-PM/EM	160M4X10	WT15IP
ZTD02-360-XP40-SP11-02	●	36	40	47	70	108	78	178	SPGT110408-PM/EM	160M4X10	WT15IP
ZTD02-370-XP40-SP11-02	●	37	40	47	70	110	80	180	SPGT110408-PM/EM	160M4X10	WT15IP
ZTD02-380-XP40-SP11-02	●	38	40	47	70	112	82	182	SPGT110408-PM/EM	160M4X10	WT15IP
ZTD02-390-XP40-SP11-02	●	39	40	47	70	114	84	184	SPGT110408-PM/EM	160M4X10	WT15IP
ZTD02-400-XP40-SP11-02	●	40	40	47	70	116	86	186	SPGT110408-PM/EM	160M4X10	WT15IP
ZTD02-410-XP40-SP11-02	●	41	40	47	70	118	88	188	SPGT110408-PM/EM	160M4X10	WT15IP
ZTD02-420-XP40-SP14-02	●	42	40	52	70	130	90	200	SPGT140512-PM/EM	160M5X13	WT20IP
ZTD02-430-XP40-SP14-02	●	43	40	52	70	132	92	202	SPGT140512-PM/EM	160M5X13	WT20IP
ZTD02-440-XP40-SP14-02	●	44	40	52	70	134	94	204	SPGT140512-PM/EM	160M5X13	WT20IP
ZTD02-450-XP40-SP14-02	●	45	40	52	70	136	96	206	SPGT140512-PM/EM	160M5X13	WT20IP
ZTD02-460-XP40-SP14-02	●	46	40	52	70	138	98	208	SPGT140512-PM/EM	160M5X13	WT20IP
ZTD02-470-XP40-SP14-02	●	47	40	52	70	140	100	210	SPGT140512-PM/EM	160M5X13	WT20IP
ZTD02-480-XP40-SP14-02	●	48	40	52	70	142	102	212	SPGT140512-PM/EM	160M5X13	WT20IP
ZTD02-490-XP40-SP14-02	●	49	40	52	70	144	104	214	SPGT140512-PM/EM	160M5X13	WT20IP
ZTD02-500-XP40-SP14-02	●	50	40	52	70	146	106	216	SPGT140512-PM/EM	160M5X13	WT20IP

● Ex Stock / ab Lager ○ On demand / auf Anfrage

### ZTD03

3D

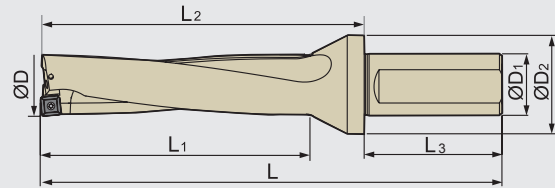
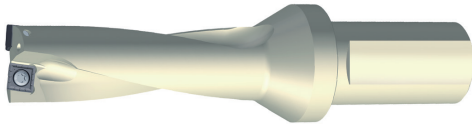

Type Typ	Stock Lager	Dimension Abmessung (mm)							Insert WSP	Screw Schraube	Wrench Schlüssel
		ØD	ØD <sub>1</sub>	ØD <sub>2</sub>	L <sub>3</sub>	L <sub>2</sub>	L <sub>1</sub>	L			
ZTD03-130-XP20-SP05-02	●	13	20	25	50	67	44	111	SPGT050204-PM/PE	I60M2.0×4.3	WT06IP
ZTD03-140-XP20-SP05-02	●	14	20	25	50	67	47	114	SPGT050204-PM/PE	I60M2.0×4.3	WT06IP
ZTD03-150-XP20-SP05-02	●	15	20	25	50	64	50	114	SPGT050204-PM/PE	I60M2.0×4.3	WT06IP
ZTD03-160-XP20-SP05-02	●	16	20	25	50	67	53	120	SPGT050204-PM/PE	I60M2.0×4.3	WT06IP
ZTD03-170-XP25-SP06-02	●	17	25	32	56	79	56	135	SPGT060204-PM/EM	I60M2.2×5.5	WT07IP
ZTD03-180-XP25-SP06-02	●	18	25	32	56	82	59	138	SPGT060204-PM/EM	I60M2.2×5.5	WT07IP
ZTD03-190-XP25-SP06-02	●	19	25	32	56	84	62	140	SPGT060204-PM/EM	I60M2.2×5.5	WT07IP
ZTD03-200-XP25-SP06-02	●	20	25	32	56	87	65	143	SPGT060204-PM/EM	I60M2.2×5.5	WT07IP
ZTD03-210-XP25-SP06-02	●	21	25	32	56	90	68	146	SPGT060204-PM/EM	I60M2.2×5.5	WT07IP
ZTD03-220-XP25-SP06-02	●	22	25	32	56	93	71	149	SPGT060204-PM/EM	I60M2.2×5.5	WT07IP
ZTD03-230-XP25-SP07-02	●	23	25	40	56	96	74	153	SPGT07T308-PM/EM	I60M2.5×6.5	WT07IP
ZTD03-240-XP25-SP07-02	●	24	25	40	56	102	77	159	SPGT07T308-PM/EM	I60M2.5×6.5	WT07IP
ZTD03-250-XP25-SP07-02	●	25	25	40	56	102	80	159	SPGT07T308-PM/EM	I60M2.5×6.5	WT07IP
ZTD03-260-XP25-SP07-02	●	26	25	40	56	105	83	162	SPGT07T308-PM/EM	I60M2.5×6.5	WT07IP
ZTD03-270-XP25-SP07-02	●	27	25	40	56	108	86	165	SPGT07T308-PM/EM	I60M2.5×6.5	WT07IP
ZTD03-280-XP25-SP07-02	●	28	25	40	56	111	89	168	SPGT07T308-PM/EM	I60M2.5×6.5	WT07IP
ZTD03-290-XP32-SP07-02	●	29	32	45	60	117	92	178	SPGT07T308-PM/EM	I60M2.5×6.5	WT07IP
ZTD03-300-XP32-SP09-02	●	30	32	45	60	120	95	181	SPGT090408-PM/EM	I60M3.5×8	WT15IP
ZTD03-310-XP32-SP09-02	●	31	32	45	60	123	98	184	SPGT090408-PM/EM	I60M3.5×8	WT15IP
ZTD03-320-XP32-SP09-02	●	32	32	45	60	126	101	187	SPGT090408-PM/EM	I60M3.5×8	WT15IP
ZTD03-330-XP32-SP09-02	●	33	32	45	60	129	104	190	SPGT090408-PM/EM	I60M3.5×8	WT15IP
ZTD03-340-XP32-SP09-02	●	34	32	45	60	132	107	193	SPGT090408-PM/EM	I60M3.5×8	WT15IP
ZTD03-350-XP32-SP09-02	●	35	32	45	60	135	110	196	SPGT090408-PM/EM	I60M3.5×8	WT15IP
ZTD03-360-XP32-SP09-02	●	36	32	45	60	138	113	199	SPGT090408-PM/EM	I60M3.5×8	WT15IP
ZTD03-370-XP40-SP11-02	●	37	40	55	70	147	117	217	SPGT110408-PM/EM	I60M4×10	WT15IP
ZTD03-380-XP40-SP11-02	●	38	40	55	70	150	119	220	SPGT110408-PM/EM	I60M4×10	WT15IP
ZTD03-390-XP40-SP11-02	●	39	40	55	70	153	122	223	SPGT110408-PM/EM	I60M4×10	WT15IP
ZTD03-400-XP40-SP11-02	●	40	40	55	70	160	125	231	SPGT110408-PM/EM	I60M4×10	WT15IP
ZTD03-410-XP40-SP11-02	●	41	40	55	70	158	128	229	SPGT110408-PM/EM	I60M4×10	WT15IP
ZTD03-420-XP40-SP11-02	●	42	40	55	70	161	131	232	SPGT110408-PM/EM	I60M4×10	WT15IP
ZTD03-430-XP40-SP11-02	●	43	40	55	70	169	134	240	SPGT110408-PM/EM	I60M4×10	WT15IP
ZTD03-440-XP40-SP14-02	●	44	40	60	70	178	138	248	SPGT140512-PM/EM	I60M5×13	WT20IP
ZTD03-450-XP40-SP14-02	●	45	40	60	70	181	141	251	SPGT140512-PM/EM	I60M5×13	WT20IP
ZTD03-460-XP40-SP14-02	●	46	40	60	70	184	144	254	SPGT140512-PM/EM	I60M5×13	WT20IP
ZTD03-470-XP40-SP14-02	●	47	40	60	70	187	147	257	SPGT140512-PM/EM	I60M5×13	WT20IP
ZTD03-480-XP40-SP14-02	●	48	40	60	70	189	149	260	SPGT140512-PM/EM	I60M5×13	WT20IP
ZTD03-490-XP40-SP14-02	●	49	40	60	70	192	152	263	SPGT140512-PM/EM	I60M5×13	WT20IP
ZTD03-500-XP40-SP14-02	●	50	40	60	70	195	155	266	SPGT140512-PM/EM	I60M5×13	WT20IP





# Drilling · Bohren

Indexable drill · Wendeschneidplattenbohrer

## ZTD04

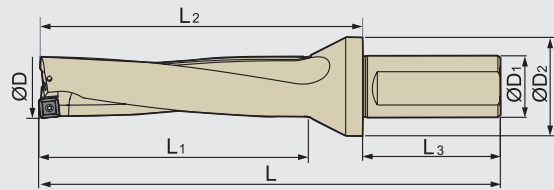
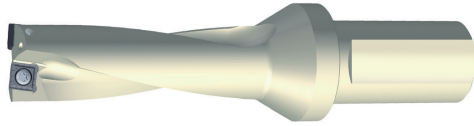
4D



Type Typ	Stock Lager	Dimension Abmessung (mm)							Insert WSP	Screw Schraube 	Wrench Schlüssel 
		ØD	ØD1	ØD2	L3	L2	L1	L			
ZTD04-130-XP20-SP05-02	○	13	20	25	50	74	57	124	SPGT050204-PM/EM	I60M2.0×4.3	WT06IP
ZTD04-140-XP20-SP05-02	●	14	20	25	50	78	61	128	SPGT050204-PM/EM	I60M2.0×4.3	WT06IP
ZTD04-150-XP20-SP05-02	●	15	20	25	50	82	65	132	SPGT050204-PM/EM	I60M2.0×4.3	WT06IP
ZTD04-160-XP20-SP05-02	●	16	20	25	50	86	69	136	SPGT050204-PM/EM	I60M2.0×4.3	WT06IP
ZTD04-170-XP25-SP06-02	●	17	25	32	56	95	73	152	SPGT060204-PM/EM	I60M2.2×5.5	WT07IP
ZTD04-180-XP25-SP06-02	●	18	25	32	56	99	77	156	SPGT060204-PM/EM	I60M2.2×5.5	WT07IP
ZTD04-190-XP25-SP06-02	●	19	25	32	56	103	81	160	SPGT060204-PM/EM	I60M2.2×5.5	WT07IP
ZTD04-200-XP25-SP06-02	●	20	25	32	56	107	85	163	SPGT060204-PM/EM	I60M2.2×5.5	WT07IP
ZTD04-210-XP25-SP06-02	●	21	25	32	56	111	89	167	SPGT060204-PM/EM	I60M2.2×5.5	WT07IP
ZTD04-220-XP25-SP06-02	●	22	25	32	56	115	93	171	SPGT060204-PM/EM	I60M2.2×5.5	WT07IP
ZTD04-230-XP25-SP07-02	●	23	25	40	56	119	97	176	SPGT07T308-PM/EM	I60M2.5×6.5	WT07IP
ZTD04-240-XP25-SP07-02	●	24	25	40	56	123	101	180	SPGT07T308-PM/EM	I60M2.5×6.5	WT07IP
ZTD04-250-XP25-SP07-02	●	25	25	40	56	127	105	184	SPGT07T308-PM/EM	I60M2.5×6.5	WT07IP
ZTD04-260-XP25-SP07-02	●	26	25	40	56	131	109	188	SPGT07T308-PM/EM	I60M2.5×6.5	WT07IP
ZTD04-270-XP25-SP07-02	●	27	25	40	56	135	113	192	SPGT07T308-PM/EM	I60M2.5×6.5	WT07IP
ZTD04-280-XP25-SP07-02	●	28	32	45	60	143	118	203	SPGT070408-PM/EM	I60M2.5×6.5	WT07IP
ZTD04-290-XP32-SP07-02	●	29	32	45	60	146	121	207	SPGT07T308-PM/EM	I60M2.5×6.5	WT07IP
ZTD04-300-XP32-SP09-02	●	30	32	45	60	150	125	211	SPGT090408-PM/EM	I60M3.5×8	WT15IP
ZTD04-310-XP32-SP09-02	●	31	32	45	60	154	129	215	SPGT090408-PM/EM	I60M3.5×8	WT15IP
ZTD04-320-XP32-SP09-02	●	32	32	45	60	158	133	219	SPGT090408-PM/EM	I60M3.5×8	WT15IP
ZTD04-330-XP32-SP09-02	●	33	32	45	60	162	137	223	SPGT090408-PM/EM	I60M3.5×8	WT15IP
ZTD04-340-XP32-SP09-02	●	34	32	45	60	166	141	227	SPGT090408-PM/EM	I60M3.5×8	WT15IP
ZTD04-350-XP32-SP09-02	●	35	32	45	60	170	145	231	SPGT090408-PM/EM	I60M3.5×8	WT15IP
ZTD04-360-XP32-SP09-02	●	36	32	45	60	174	149	235	SPGT090408-PM/EM	I60M3.5×8	WT15IP
ZTD04-370-XP40-SP11-02	●	37	40	55	70	184	154	254	SPGT110408-PM/EM	I60M4×10	WT15IP
ZTD04-380-XP40-SP11-02	●	38	40	55	70	188	158	258	SPGT110408-PM/EM	I60M4×10	WT15IP
ZTD04-390-XP40-SP11-02	●	39	40	55	70	196	161	267	SPGT110408-PM/EM	I60M4×10	WT15IP
ZTD04-400-XP40-SP11-02	●	40	40	55	70	200	165	271	SPGT110408-PM/EM	I60M4×10	WT15IP
ZTD04-410-XP40-SP11-02	●	41	40	55	70	199	169	270	SPGT110408-PM/EM	I60M4×10	WT15IP
ZTD04-420-XP40-SP11-02	●	42	40	55	70	208	173	279	SPGT110408-PM/EM	I60M4×10	WT15IP
ZTD04-430-XP40-SP11-02	●	43	40	55	70	212	177	283	SPGT110408-PM/EM	I60M4×10	WT15IP
ZTD04-440-XP40-SP14-02	●	44	40	60	70	222	182	292	SPGT140512-PM/EM	I60M5×13	WT20IP
ZTD04-450-XP40-SP14-02	●	45	40	60	70	226	186	296	SPGT140512-PM/EM	I60M5×13	WT20IP
ZTD04-460-XP40-SP14-02	●	46	40	60	70	230	190	300	SPGT140512-PM/EM	I60M5×13	WT20IP
ZTD04-470-XP40-SP14-02	●	47	40	60	70	234	194	304	SPGT140512-PM/EM	I60M5×13	WT20IP
ZTD04-480-XP40-SP14-02	●	48	40	60	70	237	198	308	SPGT140512-PM/EM	I60M5×13	WT20IP
ZTD04-490-XP40-SP14-02	●	49	40	60	70	241	202	312	SPGT140512-PM/EM	I60M5×13	WT20IP
ZTD04-500-XP40-SP14-02	●	50	40	60	70	245	206	316	SPGT140512-PM/EM	I60M5×13	WT20IP



Indexable drills  
WPS-Bohrer

### ZTD05

5D

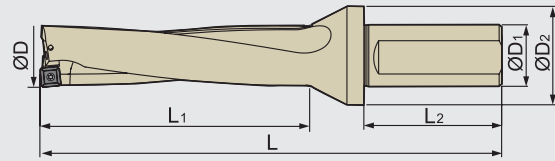
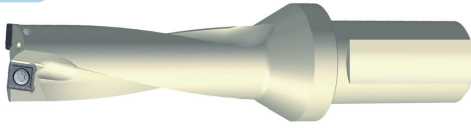

Type Typ	Stock Lager	Dimension Abmessung (mm)						Insert WSP	Screw Schraube	Wrench Schlüssel
		ØD	ØD <sub>1</sub>	ØD <sub>2</sub>	L <sub>1</sub>	L <sub>2</sub>	L			
ZTD05-170-XP25-SP06-02	●	17	25	32	91	56	169	SPGT060204-PM/EM	I60M2.2×5.5	WT07IP
ZTD05-180-XP25-SP06-02	●	18	25	32	96	56	174	SPGT060204-PM/EM	I60M2.2×5.5	WT07IP
ZTD05-190-XP25-SP06-02	●	19	25	32	101	56	179	SPGT060204-PM/EM	I60M2.2×5.5	WT07IP
ZTD05-200-XP25-SP06-02	●	20	25	32	106	56	184	SPGT060204-PM/EM	I60M2.2×5.5	WT07IP
ZTD05-210-XP25-SP06-02	●	21	25	32	111	56	189	SPGT060204-PM/EM	I60M2.2×5.5	WT07IP
ZTD05-220-XP25-SP07-02	●	22	25	32	115	56	194	SPGT07T308-PM/EM	I60M2.5×6.5	WT07IP
ZTD05-230-XP25-SP07-02	●	23	25	32	120	56	199	SPGT07T308-PM/EM	I60M2.5×6.5	WT07IP
ZTD05-240-XP25-SP07-02	●	24	25	32	125	56	204	SPGT07T308-PM/EM	I60M2.5×6.5	WT07IP
ZTD05-250-XP25-SP07-02	●	25	25	32	130	56	209	SPGT07T308-PM/EM	I60M2.5×6.5	WT07IP
ZTD05-260-XP25-SP07-02	●	26	25	32	135	56	214	SPGT07T308-PM/EM	I60M2.5×6.5	WT07IP
ZTD05-270-XP25-SP07-02	●	27	25	32	140	56	219	SPGT07T308-PM/EM	I60M2.5×6.5	WT07IP
ZTD05-280-XP32-SP09-02	●	28	32	37	145	60	231	SPGT090408-PM/EM	I60M3.5×8	WT15IP
ZTD05-290-XP32-SP09-02	●	29	32	37	150	60	236	SPGT090408-PM/EM	I60M3.5×8	WT15IP
ZTD05-300-XP32-SP09-02	●	30	32	37	155	60	241	SPGT090408-PM/EM	I60M3.5×8	WT15IP
ZTD05-310-XP32-SP09-02	●	31	32	37	160	60	246	SPGT090408-PM/EM	I60M3.5×8	WT15IP
ZTD05-320-XP32-SP09-02	●	32	32	37	165	60	251	SPGT090408-PM/EM	I60M3.5×8	WT15IP
ZTD05-330-XP32-SP09-02	●	33	32	37	170	60	256	SPGT090408-PM/EM	I60M3.5×8	WT15IP
ZTD05-340-XP40-SP11-02	●	34	40	47	176	70	276	SPGT110408-PM/EM	I60M4×10	WT15IP
ZTD05-350-XP40-SP11-02	●	35	40	47	181	70	281	SPGT110408-PM/EM	I60M4×10	WT15IP
ZTD05-360-XP40-SP11-02	●	36	40	47	186	70	286	SPGT110408-PM/EM	I60M4×10	WT15IP
ZTD05-370-XP40-SP11-02	●	37	40	47	191	70	291	SPGT110408-PM/EM	I60M4×10	WT15IP
ZTD05-380-XP40-SP11-02	●	38	40	47	196	70	296	SPGT110408-PM/EM	I60M4×10	WT15IP
ZTD05-390-XP40-SP11-02	●	39	40	47	201	70	301	SPGT110408-PM/EM	I60M4×10	WT15IP
ZTD05-400-XP40-SP11-02	●	40	40	47	206	70	306	SPGT110408-PM/EM	I60M4×10	WT15IP
ZTD05-410-XP40-SP11-02	○	41	40	47	211	70	311	SPGT110408-PM/EM	I60M4×10	WT15IP
ZTD05-420-XP40-SP14-02	○	42	40	52	216	70	326	SPGT140512-PM/EM	I60M5×13	WT20IP
ZTD05-430-XP40-SP14-02	○	43	40	52	221	70	331	SPGT140512-PM/EM	I60M5×13	WT20IP
ZTD05-440-XP40-SP14-02	○	44	40	52	226	70	336	SPGT140512-PM/EM	I60M5×13	WT20IP
ZTD05-450-XP40-SP14-02	○	45	40	52	231	70	342	SPGT140512-PM/EM	I60M5×13	WT20IP
ZTD05-460-XP40-SP14-02	○	46	40	52	236	70	346	SPGT140512-PM/EM	I60M5×13	WT20IP
ZTD05-470-XP40-SP14-02	○	47	40	52	241	70	351	SPGT140512-PM/EM	I60M5×13	WT20IP
ZTD05-480-XP40-SP14-02	○	48	40	52	246	70	356	SPGT140512-PM/EM	I60M5×13	WT20IP
ZTD05-490-XP40-SP14-02	○	49	40	52	251	70	361	SPGT140512-PM/EM	I60M5×13	WT20IP
ZTD05-500-XP40-SP14-02	○	50	40	52	256	70	366	SPGT140512-PM/EM	I60M5×13	WT20IP

● Ex Stock / ab Lager ○ On demand / auf Anfrage



### ZD03

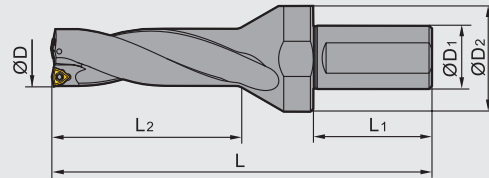

Type Typ	Stock Lager	Basic dimension(mm) Abmessungen						Inserts WSP	Screw Schraube	Wrench Schlüssel
		D	D <sub>1</sub>	D <sub>2</sub>	L <sub>1</sub>	L <sub>2</sub>	L			
ZD03-160-XP25-WC03-02	●	16	25	32	56	52	129	WCMX030208	I60M2.5×6.5	WT07IP
ZD03-170-XP25-WC03-02	●	17	25	32	56	55	133	WCMX030208	I60M2.5×6.5	WT07IP
ZD03-180-XP25-WC03-02	●	18	25	32	56	58	137	WCMX030208	I60M2.5×6.5	WT07IP
ZD03-190-XP25-WC03-02	●	19	25	32	56	61	140	WCMX030208	I60M2.5×6.5	WT07IP
ZD03-200-XP25-WC03-02	●	20	25	32	56	64	143	WCMX030208	I60M2.5×6.5	WT07IP
ZD03-210-XP25-WC04-02	●	21	25	45	56	67	153	WCMX040208	I60M2.5×6.5T	WT08IP
ZD03-220-XP25-WC04-02	●	22	25	45	56	70	156	WCMX040208	I60M2.5×6.5T	WT08IP
ZD03-230-XP25-WC04-02	●	23	25	45	56	73	159	WCMX040208	I60M2.5×6.5T	WT08IP
ZD03-240-XP25-WC04-02	●	24	25	45	56	76	162	WCMX040208	I60M2.5×6.5T	WT08IP
ZD03-250-XP25-WC04-02	●	25	25	45	56	79	165	WCMX040208	I60M2.5×6.5T	WT08IP
ZD03-260-XP32-WC05-02	●	26	32	55	60	83	176	WCMX050308	I60M3×7	WT09IP
ZD03-270-XP32-WC05-02	●	27	32	55	60	86	180	WCMX050308	I60M3×7	WT09IP
ZD03-280-XP32-WC05-02	●	28	32	55	60	89	184	WCMX050308	I60M3×7	WT09IP
ZD03-290-XP32-WC05-02	●	29	32	55	60	92	188	WCMX050308	I60M3×7	WT09IP
ZD03-300-XP32-WC05-02	●	30	32	55	60	95	192	WCMX050308	I60M3×7	WT09IP
ZD03-310-XP40-WC06-02	●	31	40	60	70	98	203	WCMX06T308	I60M3×7	WT09IP
ZD03-320-XP40-WC06-02	●	32	40	60	70	101	206	WCMX06T308	I60M3×7	WT09IP
ZD03-330-XP40-WC06-02	●	33	40	60	70	104	209	WCMX06T308	I60M3×7	WT09IP
ZD03-340-XP40-WC06-02	●	34	40	60	70	107	212	WCMX06T308	I60M3×7	WT09IP
ZD03-350-XP40-WC06-02	●	35	40	60	70	110	215	WCMX06T308	I60M3×7	WT09IP
ZD03-360-XP40-WC06-02	●	36	40	60	70	113	218	WCMX06T308	I60M3×7	WT09IP
ZD03-370-XP40-WC06-02	●	37	40	60	70	116	221	WCMX06T308	I60M3×7	WT09IP
ZD03-380-XP40-WC06-02	●	38	40	60	70	119	225	WCMX06T308	I60M3×7	WT09IP
ZD03-390-XP40-WC06-02	●	39	40	60	70	122	228	WCMX06T308	I60M3×7	WT09IP

● Ex Stock / ab Lager   ○ On demand / auf Anfrage



### ZD03

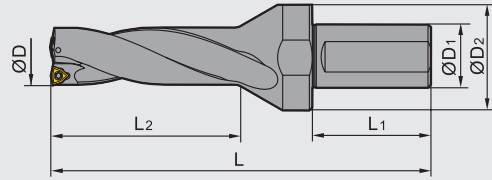
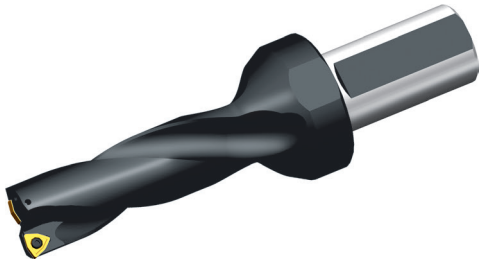

Type Typ	Stock Lager	Basic dimension(mm) Abmessungen						Inserts WSP	Screw Schraube	Wrench Schlüssel
		D	D <sub>1</sub>	D <sub>2</sub>	L <sub>1</sub>	L <sub>2</sub>	L			
ZD03-400-XP40-WC06-02	●	40	40	60	70	125	231	WCMX06T308	I60M3×7	WT09IP
ZD03-410-XP40-WC06-02	●	41	40	60	70	128	234	WCMX06T308	I60M3×7	WT09IP
ZD03-420-XP40-WC08-02	●	42	40	60	70	131	239	WCMX080412	I60M3.5×10.4	WT15IP
ZD03-430-XP40-WC08-02	●	43	40	60	70	134	242	WCMX080412	I60M3.5×10.4	WT15IP
ZD03-440-XP40-WC08-02	●	44	40	60	70	137	245	WCMX080412	I60M3.5×10.4	WT15IP
ZD03-450-XP40-WC08-02	●	45	40	60	70	140	248	WCMX080412	I60M3.5×10.4	WT15IP
ZD03-460-XP40-WC08-02	●	46	40	60	70	143	251	WCMX080412	I60M3.5×10.4	WT15IP
ZD03-470-XP40-WC08-02	●	47	40	60	70	146	253	WCMX080412	I60M3.5×10.4	WT15IP
ZD03-480-XP40-WC08-02	●	48	40	70	70	149	255	WCMX080412	I60M3.5×10.4	WT15IP
ZD03-490-XP40-WC08-02	○	49	40	70	70	152	257	WCMX080412	I60M3.5×10.4	WT15IP
ZD03-500-XP40-WC08-02	●	50	40	70	70	155	259	WCMX080412	I60M3.5×10.4	WT15IP
ZD03-510-XP40-WC08-02	●	51	40	70	70	158	261	WCMX080412	I60M3.5×10.4	WT15IP
ZD03-520-XP40-WC08-02	○	52	40	70	70	161	263	WCMX080412	I60M3.5×10.4	WT15IP
ZD03-530-XP40-WC08-02	○	53	40	70	70	164	265	WCMX080412	I60M3.5×10.4	WT15IP
ZD03-540-XP40-WC08-02	●	54	40	70	70	167	267	WCMX080412	I60M3.5×10.4	WT15IP
ZD03-550-XP40-WC08-02	○	55	40	70	70	170	269	WCMX080412	I60M3.5×10.4	WT15IP
ZD03-560-XP40-WC08-02	○	56	40	70	70	173	271	WCMX080412	I60M3.5×10.4	WT15IP
ZD03-570-XP40-WC08-02	○	57	40	70	70	176	273	WCMX080412	I60M3.5×10.4	WT15IP
ZD03-580-XP40-WC08-02	●	58	40	70	70	179	275	WCMX080412	I60M3.5×10.4	WT15IP



# Drilling · Bohren

Indexable drill · Wendeschneidplattenbohrer

## Inserts Drills Code Key · ISO Kennzeichnung Wendeschneidplatten

Insert shape · Plattenform	
Code	Insert shap Plattenform
S	
W	

Tolerance · Toleranz							
Code	m Tolerance(mm) Toleranz	Øl.C Tolerance(mm) Toleranz	S Tolerance(mm) Toleranz	Code	m Tolerance(mm) Toleranz	Øl.C Tolerance(mm) Toleranz	S Tolerance(mm) Toleranz
A	±0.005	±0.025	±0.025	J	±0.005	±0.05-±0.13	±0.025
F	±0.005	±0.013	±0.025	K	±0.013	±0.05-±0.13	±0.025
C	±0.013	±0.025	±0.025	L	±0.025	±0.05-±0.13	±0.025
H	±0.013	±0.013	±0.025	M	±0.08-±0.18	±0.05-±0.13	±0.13
E	±0.025	±0.025	±0.025	N	±0.08-±0.18	±0.05-±0.13	±0.025
G	±0.025	±0.025	±0.13	U	±0.13-±0.38	±0.08-±0.25	±0.13



Clearance angle of main cutting edge Freiwinkel der Hauptschneide			
Code	Clearance angle Freiwinkel	Code	Clearance angle Freiwinkel
A		B	
C		D	
E		F	
G		N	
P		O	Other clearance angle Anderer Freiwinkel

Chipbreaker and clamping system Spanformstufen und Klemmung							
Metric · Metrisch							
Code	With / Without hole Mit / Ohne Loch	With / Without chipbreaker Mit / Ohne Spanbrecher	Section plane of Insert Plattenform	Code	With / Without hole Mit / Ohne Loch	With / Without chipbreaker Mit / Ohne Spanbrecher	Section plane of Insert Plattenform
B	✓	-		N	-	-	
H	✓	Single-side Einseitig		R	-	Single-side Einseitig	
C	✓	-		F	-	Double-side Doppelseitig	
J	✓	Double-side Doppelseitig		A	✓	-	
W	✓	-		M	-	Single-side Einseitig	
T	✓	Single-side Einseitig		G	✓	Double-side Doppelseitig	
Q	✓	-		X	---	---	Special Spezial
U	✓	Double-side Doppelseitig					

C

Indexable drills  
WPS-Bohrer

Length of cutting edge Schneidenlänge		
Code	Length · Länge	
	W	S
03	3.8	
04	4.3	
05	5.4	
06	6.5	6.35
08	8.7	8.0
09		9.525
12		12.7

Insert thickness Dicke			
Thickness is defined as height from bottom of insert to the highest part of cutting edge Dicke ist definiert als Höhe von der Unterseite der WSP bis zur höchsten Stelle der Scheikante			
Code	Insert thickness WSP Dicke (mm)	Code	Insert thickness WSP Dicke (mm)
00	0.79	05	5.96
T0	0.99	T5	5.95
01	1.59	06	6.35
T1	1.98	T6	6.75
02	2.38	07	7.94
T2	2.58	09	9.52
03	3.18	T9	9.72
T3	3.97	11	11.11
04	4.76	12	12.70
T4	4.96		

**08 04 12 R - PG**

Nose radius Schneidenradius	
Code	Description Beschreibung
04	0.4mm
08	0.8mm
12	1.2mm

Cutting direction Vorschubrichtung	
Code	Description Beschreibung
R	Right hand / Rechts
L	Left hand / Links
N	Neutral

Chipbreaker code  
Spanformstufe

# Drilling · Bohren

Indexable drill · Wendeschneidplattenbohrer

## ■ ZTD 02 / 03 / 04 / 05

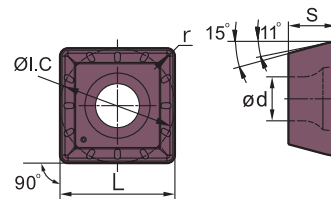
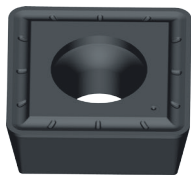

Type Typ	Dimension Abmessung (mm)						Grade Sorte	
	L	ØI.C	s	ød	α	r	YBG205 outer insert Außenschnide	YBG212 inner insert Innenschnide
SPGT050204-PM	5	5	2.4	2.2	15°, 7°	0.4	•	•
SPGT060204-PM	6	6	2.4	2.6	15°, 11°	0.4	•	•
SPGT07T308-PM	7.94	7.94	4	2.8	15°, 11°	0.8	•	•
SPGT090408-PM	9.8	9.8	4.3	4.2	15°, 11°	0.8	•	•
SPGT110408-PM	11.5	11.5	4.8	4.4	15°, 11°	0.8	•	•
SPGT140512-PM	14.3	14.3	5.2	5.75	15°, 11°	1.2	•	•

• ex stock / ab Lager ○ on demand / auf Anfrage

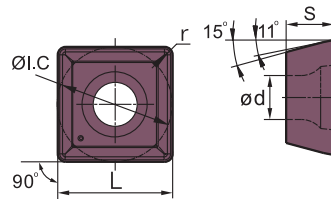

Type Typ	Dimension Abmessung (mm)						Grade Sorte	
	L	ØI.C	s	ød	r	YBG205 outer insert Außenschnide	YBG212 inner insert Innenschnide	
SPGT050204-EM	5	5	2.38	2.2	0.4	•	•	
SPGT060204-EM	6	6	2.38	2.6	0.4	•	•	
SPGT07T308-EM	7.94	7.94	3.97	2.8	0.8	•	•	
SPGT090408-EM	9.8	9.8	4.3	4.2	0.8	•	•	
SPGT110408-EM	11.5	11.5	4.76	4.4	0.8	•	•	
SPGT140512-EM	14.3	14.3	5.2	5.75	1.2	•	•	

• ex stock / ab Lager ○ on demand / auf Anfrage

## ■ Material Overview · Material Übersicht

✓ = Very suitable · Sehr empfohlen  
 ✓ = Suitable · Empfohlen

Grade Sorte	Workpiece material · Werkstückstoff									
	Mild steel Baustahl HB≤180	Carbon steel Alloy Steel Kohlenstoff-, Legierter Stahl	Hardened steel · Gehärteter Stahl			Stainless steel Rostfreier Stahl	Cast iron Gusseisen	Nodular cast iron GGG Kugelgrah- phtguss	Aluminum alloy Aluleg.	Copper alloy Kupferleg.
SPGT*- PM	✓	✓				✓	✓	✓		

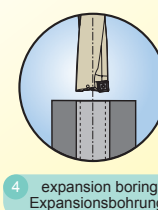
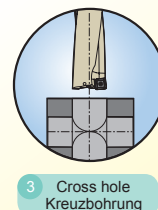
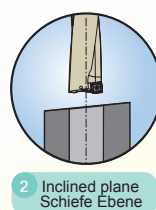
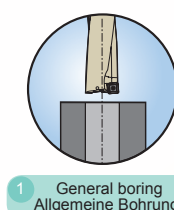
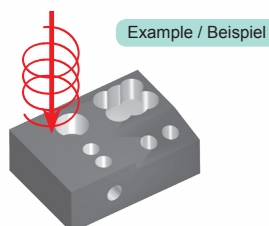

### Indexable inserts for drilling · WSP zum Bohren

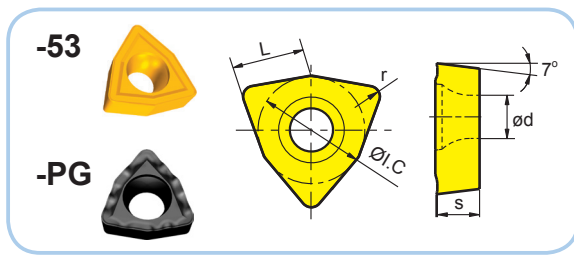

Workpiece Material Werkstoffe	Ideal Machining Condition Gute Bearbeitungsbedingungen		Normal Machining Condition Normale Bearbeitungsbedingungen		Unfavorable Machining Condition Ungünstige Bearbeitungsbedingungen	
	●	●	●	●	●	●
<b>P</b> Steel / Stahl	●	●	●	●	●	●
<b>M</b> Stainless Steel Rostfreier Stahl	●	●	●	●	●	●
<b>K</b> Cast Iron Gusseisen	●	●	●	●	●	●
<b>N</b> Non-ferrite material Ne Metalle						●
<b>S</b> Heat-resistant steel Wärmfester Stahl	●					

Type Typ	Basic dimension(mm) · Basis Abmessungen					Grade · Sorte					
	L	I.C	s	d	r	YBG202	YBG205	YBG201	YBD252	YBG40	YD201
WCMX030208R-53	3.8	5.56	2.38	2.8	0.8	●		●	●	○	○
WCMX040208R-53	4.3	6.35	2.38	3.1	0.8	●		●	●	○	○
WCMX050308R-53	5.4	7.94	3.18	3.2	0.8	●		●	●	○	○
WCMX06T308R-53	6.5	9.525	3.97	3.7	0.8	●		●	●	○	○
WCMX080412R-53	8.7	12.7	4.76	4.3	1.2	●		●	●	○	○
WCMX030208-D	3.8	5.56	2.38	2.8	0.8				○	○	
WCMX040208-D	4.3	6.35	2.38	3.1	0.8				○	○	
WCMX050308-D	5.4	7.94	3.18	3.2	0.8				○	○	
WCMX06T308-D	6.5	9.525	3.97	3.7	0.8				○	○	
WCMX080412-D	8.7	12.7	4.76	4.3	1.2				○	○	
WCMX030208R-PG	3.8	5.56	2.38	2.8	0.8	●			○		
WCMX040208R-PG	4.3	6.35	2.38	3.1	0.8	●			○		
WCMX050308R-PG	5.4	7.94	3.18	3.2	0.8	●	○		○		
WCMX06T308R-PG	6.5	9.525	3.97	3.7	0.8	●			○		
WCMX080412R-PG	8.7	12.7	4.76	4.3	1.2	●			○		

### -PG chipbreaker -PG Spanbrecher

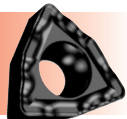

Unique design of waveform edge ensure high edge strength and good chip breaking performance for machining carbon steel and alloy steel.

Wellenförmige Schneide mit hoher Stabilität und Spankontrolle zur Bearbeitung von Kohlenstoffstahl, legiertem Stahl und Guss

### -53 chipbreaker -53 Spanbrecher



Sharp cutting edge benefits to achieve low roughness surface, mainly applicable for low load cutting of aluminum alloy, mild steel, stainless steel and cast iron.

Scharfe Schneidkante zur Erzielung exklusiver Oberflächen. Zur Bearbeitung von Alulegierungen, Baustahl, rostfreiem Stahl und Grauguss.

### -D chipbreaker -D Spanbrecher

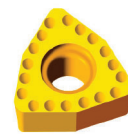

Inserts for outer positioning with optimized chipbreaker geometry. And good chip breaking performance for machining, steel, stainless steel, cast iron for common cutting speed .

Optimierte Geometrie als Außenschneide einsetzbar. Gute Spankontrolle bei Stahl, rostfreiem Stahl, Grauguss bei mittleren Schnittgeschwindigkeiten.

# Drilling · Bohren

General technical information · Allgemeine Technische Information

Comparison table for drilling Insert - Grades  
Bohrwendepplatten Übersichtstabelle - Sorten

Workpiece material Werkstück Material	ISO	Coating · Beschichtung		Cermet Cermet	uncoated carbide unb. Hartmetall	PCBN & PCD PCBN & PKD
		CVD	PVD			
<b>P</b> Steel · Stahl	P01					
	P10		YBG202 YBG205 YBG212			
	P20	YBD252				
	P30					
	P40					
<b>M</b> Stainless Steel Rostfreier Stahl	M01					
	M10		YBG202 YBG205 YBG212			
	M20					
	M30					
	M40					
<b>K</b> Cast iron · Grauguss	K01					
	K10	YBD252		YBG202 YBG205 YBG212		
	K20					
	K30					
	K40					
<b>N</b> Hardened material Gehärtete Werkstoffe	N01					
	N10					
	N20				YD201	
	N30					
<b>S</b> Heat-resistant steel Warmfester Stahl	S01					
	S10		YBG202 YBG205			
	S20					
	S30					
<b>H</b> Non-ferrite materials Ne - Metalle	H01					
	H10					
	H20					
	H30					



# Drilling · Bohren

Indexable drill · Wendeschneidplattenbohrer

## Recommended cutting data for shallow drills · Empfohlene Schnittdaten für WSP-Bohrern

ISO	Material	Hardness HB Härte HB	Diameter Ø Durchmesser [mm]	Feed rate Vorschub fn [mm/r]	Cutting speed Schnittgeschwindigkeit Vc [m/min]
<b>P</b>	Carbon steel Kohlenstoff- stahl	80-200	16.0-23.0 24.0-30.0 31.0-38.0 39.0-46.0 47.0-58.0	0.05-0.09 0.05-0.09 0.06-0.10 0.07-0.11 0.08-0.12	200(170-240)
	Low alloy steel Niedrigleg. Stahl	150-260	16.0-23.0 24.0-30.0 31.0-38.0 39.0-46.0 47.0-58.0	0.05-0.09 0.05-0.12 0.06-0.14 0.08-0.16 0.10-0.20	170(140-220)
	High alloy steel Hochleg. Stahl	150-320	16.0-23.0 24.0-30.0 31.0-38.0 39.0-46.0 47.0-58.0	0.05-0.09 0.05-0.12 0.06-0.16 0.08-0.18 0.10-0.22	150(120-180)
	Cast steel Gussstahl	180-250	16.0-23.0 24.0-30.0 31.0-38.0 39.0-46.0 47.0-58.0	0.05-0.08 0.05-0.08 0.06-0.10 0.07-0.11 0.07-0.12	140(120-170)
<b>M</b>	Stainless steel Ferrite Martensite Rostfreier Stahl	150-270	16.0-23.0 24.0-30.0 31.0-38.0 39.0-46.0 47.0-58.0	0.05-0.09 0.05-0.12 0.06-0.16 0.08-0.18 0.10-0.22	160(110-230)
	Austenite Austenit	150-275	16.0-23.0 24.0-30.0 31.0-38.0 39.0-46.0 47.0-58.0	0.05-0.09 0.05-0.11 0.06-0.13 0.08-0.14 0.10-0.16	140(110-220)
<b>K</b>	Malleable cast iron Temperguss	150-230	16.0-23.0 24.0-30.0 31.0-38.0 39.0-46.0 47.0-58.0	0.05-0.10 0.05-0.14 0.08-0.16 0.10-0.20 0.12-0.24	160(120-220)
	Gray cast iron Grauguss	150-220	16.0-23.0 24.0-30.0 31.0-38.0 39.0-46.0 47.0-58.0	0.05-0.10 0.05-0.14 0.08-0.16 0.10-0.20 0.12-0.24	200(170-240)
	Nodular cast iron GGG Kugelgra- phitguss	160-250	16.0-23.0 24.0-30.0 31.0-38.0 39.0-46.0 47.0-58.0	0.05-0.09 0.05-0.12 0.06-0.14 0.08-0.16 0.10-0.20	160(130-200)
<b>N</b>	Al alloy Alulegierung	60-110	16.0-23.0 24.0-30.0 31.0-38.0 39.0-46.0 47.0-58.0	0.05-0.10 0.05-0.14 0.08-0.16 0.10-0.20 0.12-0.24	300(250-350)

**C**

Indexable drills  
WSP-Bohrer

# Reaming - Reiben





## Reamers - Reibahlen

<b>Solid carbide reamers overview</b>	<b>C142</b>	<b>VHM Reibahlen Übersicht</b>
Graphics identification	<b>C142</b>	Graphische Werkzeugbeschreibung
Code Key	<b>C143</b>	ISO Kennzeichnung
<b>Solid carbide reamer program</b>	<b>C144-C147</b>	<b>VHM Reibahlen Programm</b>
Recommended cutting datas	<b>C148</b>	Empfohlene Schnittdaten
<b>Technical information</b>	<b>C149-C151</b>	<b>Technische Informationen</b>
Order form for non-standard products	<b>C152</b>	Bestellformular für Sonderwerkzeuge

# Reaming · Reiben

Solid Carbide Reamers · Vollhartmetall-Reibahlen

## Solid carbide reamers overview · VHM Reibahlen Übersicht

Name Name	Type Typ	Shape Ausführung	Diameter range Durchmesser bereich Ø	Workpiece material Werkstück Material						Page Seite			
				P	M	K	N	S	H	Specification Spezifikation	Cutting datas Schnittdaten		
Right helical flute Rechts gedrallt	3101H7		Ø4-Ø20									C144	C148
Straight flute Gerade genutet	3102H7		Ø4-Ø20									C145	
Straight flute with inner hole Gerad genutet mit einem inneren Loch	3112H7		Ø4-Ø20	✓								C146	
Left helical flute Links gedrallt	3103H7		Ø4-Ø20									C147	

✓ = Very suitable · Sehr empfohlen  
 ✓ = Suitable · Empfohlen

## Solid carbide reamers icons information · VHM Reibahlen Grafische Beschreib

- Precision class of reamed hole
- Bohrungstoleranzklasse

H7

The precision class of reamed hole reaches H7 specified in GB/T1800-1804  
 Toleranzklasse H7  
 angegeben in GB/T1800-1804

- Shank · Schaft



Straight shank  
 Zylinderschaft

### Solid carbide reamer Code Key · VHM Reibahlen ISO Kennzeichnung

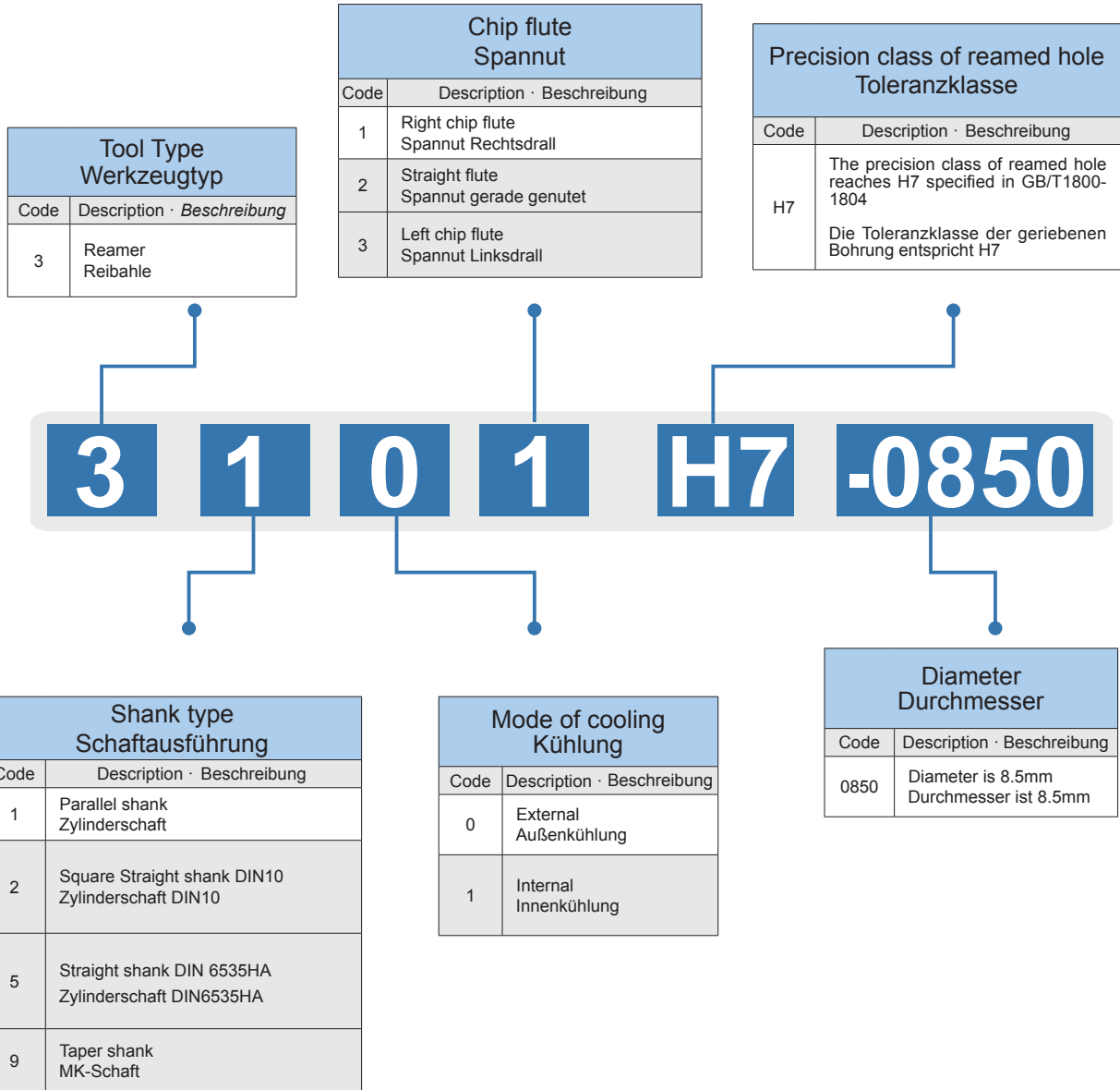

# Reaming · Reiben

Solid Carbide Reamers · Vollhartmetall-Reibahlen

## 3101H7 with Straight shank and right helical flute mit Zylinderschaft und rechtsgedrallter Spannute

H7

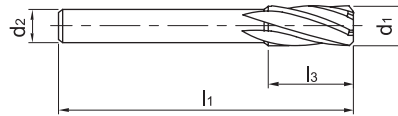

Type Typ	Basic dimension(mm) · Basis Abmessungen				Number of teeth Zähnezahl	Grade · Sorte
	d <sub>1</sub>	d <sub>2</sub> (h <sub>6</sub> )	l <sub>1</sub>	l <sub>3</sub>		YK10F
3101H7-0400	4.0	3.55	56	20	4	○
3101H7-0450	4.5	4.00	63	22	6	○
3101H7-0500	5.0	4.00	63	22	6	○
3101H7-0550	5.5	5.00	63	22	6	○
3101H7-0600	6.0	5.00	63	22	6	○
3101H7-0650	6.5	5.00	63	22	6	○
3101H7-0700	7.0	6.30	71	25	6	○
3101H7-0750	7.5	6.30	71	25	6	○
3101H7-0800	8.0	6.30	71	25	6	○
3101H7-0850	8.5	8.00	71	25	6	○
3101H7-0900	9.0	8.00	71	25	6	○
3101H7-0950	9.5	8.00	71	25	6	○
3101H7-1000	10.0	8.00	71	25	6	○
3101H7-1050	10.5	8.00	71	25	6	○
3101H7-1100	11.0	10.00	80	28	6	○
3101H7-1150	11.5	10.00	80	28	6	○
3101H7-1200	12.0	10.00	80	28	6	○
3101H7-1250	12.5	10.00	80	28	6	○
3101H7-1300	13.0	10.00	80	28	6	○
3101H7-1350	13.5	12.5	90	32	6	○
3101H7-1400	14.0	12.5	90	32	6	○
3101H7-1450	14.5	12.5	90	32	6	○
3101H7-1500	15.0	12.5	90	32	6	○
3101H7-1550	15.5	12.5	90	32	6	○
3101H7-1600	16.0	12.5	90	32	6	○
3101H7-1700	17.0	12.5	90	32	6	○
3101H7-1800	18.0	16.00	100	36	6	○
3101H7-1900	19.0	16.00	100	36	6	○
3101H7-2000	20.0	16.00	100	36	6	○

### Material Overview · Material Übersicht

✓ = Very suitable · Sehr empfohlen  
 ✓ = Suitable · Empfohlen

Grade Sorte	Workpiece material · Werkstückstoff									
	Mild steel Baustahl HB≤180	Carbon steel Alloy Steel Kohlenstoff-, Legierter Stahl	Hardened steel · Gehärteter Stahl			Stainless steel Rostfreier Stahl	Cast iron Gusseisen	Nodular cast iron GGG Kugelgra- phitguss	Aluminum alloy Aluleg.	Copper alloy Kupferleg
YK10F			~40HRC	~50HRC	~60HRC		✓	✓	✓	✓

○ On demand / auf Anfrage

● Ex Stock / ab Lager

Solid Carbide Reamers  
Vollhartmetall Reibahlen

### 3102H7 with Straight shank and flute · mit Zylinderschaft und gerader Spannute

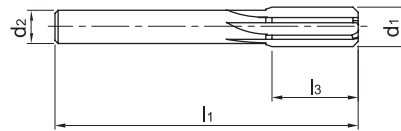
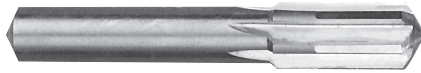

H7



Type Typ	Basic dimension(mm) · Basis Abmessungen				Number of teeth Zähnezahl	Grade · Sorte YK10F
	d1	d2(h6)	l1	l3		
3102H7-0400	4.0	3.55	56	20	4	○
3102H7-0450	4.5	4.00	63	22	6	○
3102H7-0500	5.0	4.00	63	22	6	○
3102H7-0550	5.5	5.00	63	22	6	○
3102H7-0600	6.0	5.00	63	22	6	○
3102H7-0650	6.5	5.00	63	22	6	○
3102H7-0700	7.0	6.30	71	25	6	○
3102H7-0750	7.5	6.30	71	25	6	○
3102H7-0800	8.0	6.30	71	25	6	○
3102H7-0850	8.5	8.00	71	25	6	○
3102H7-0900	9.0	8.00	71	25	6	○
3102H7-0950	9.5	8.00	71	25	6	○
3102H7-1000	10.0	8.00	71	25	6	○
3102H7-1050	10.5	8.00	71	25	6	○
3102H7-1100	11.0	10.00	80	28	6	○
3102H7-1150	11.5	10.00	80	28	6	○
3102H7-1200	12.0	10.00	80	28	6	○
3102H7-1250	12.5	10.00	80	28	6	○
3102H7-1300	13.0	10.00	80	28	6	○
3102H7-1350	13.5	12.5	90	32	6	○
3102H7-1400	14.0	12.5	90	32	6	○
3102H7-1450	14.5	12.5	90	32	6	○
3102H7-1500	15.0	12.5	90	32	6	○
3102H7-1550	15.5	12.5	90	32	6	○
3102H7-1600	16.0	12.5	90	32	6	○
3102H7-1700	17.0	12.5	90	32	6	○
3102H7-1800	18.0	16.00	100	36	6	○
3102H7-1900	19.0	16.00	100	36	6	○
3102H7-2000	20.0	16.00	100	36	6	○

#### Material Overview · Material Übersicht

✓ = Very suitable · Sehr empfohlen  
 ✓ = Suitable · Empfohlen

Grade Sorte	Workpiece material · Werkstückstoff									
	Mild steel Baustahl HB≤180	Carbon steel Alloy Steel Kohlenstoff-, Legierter Stahl	Hardened steel · Gehärteter Stahl			Stainless steel Rostfreier Stahl	Cast iron Gusseisen	Nodular cast iron GGG Kugelgra- phitguss	Aluminum alloy Aluleg.	Copper alloy Kupferleg.
YK10F			~40HRC	~50HRC	~60HRC		✓	✓	✓	✓

Code key C143  
ISO Kennzeichen

Cutting data C148  
Schnittdaten

Technical Information C149-151  
Technische Information.

Non-standart tailor made C152  
Bestellformular für Sonderwerkzeuge

○ On demand / auf Anfrage  
● Ex Stock / ab Lager



Solid Carbide Reamers  
Vollhartmetall Reibahlen

# Reaming · Reiben

Solid Carbide Reamers · Vollhartmetall-Reibahlen

## 3112H7 with Straight shank and flute · mit Zylinderschaft und gerader Spannute

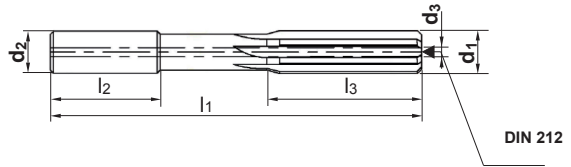

H7



Type Typ	Basic dimension(mm) · Basis Abmessungen						Number of teeth Zähnezahl	Grade · Sorte
	d <sub>1</sub> DIN 1420	d <sub>2</sub> (h <sub>6</sub> )	d <sub>3</sub>	l <sub>1</sub>	l <sub>3</sub>	l <sub>2</sub>		KRG102
3112H7-0400	4.0	4.0	0.6	70	20	28	6	●
3112H7-0500	5.0	5.0	1.0	70	22	28	6	●
3112H7-0600	6.0	6.00	1.0	100	22	36	6	●
3112H7-0700	7.0	8.00	1.3	110	25	42	6	●
3112H7-0800	8.0	8.00	1.3	110	25	42	6	●
3112H7-0900	9.0	10.00	2.0	110	25	42	6	●
3112H7-1000	10.0	10.00	2.0	110	25	38	6	●
3112H7-1100	11.0	12.00	2.0	110	28	38	6	●
3112H7-1200	12.0	12.00	2.0	110	28	38	6	●
3112H7-1300	13.0	14.00	2.0	110	28	38	6	●
3112H7-1400	14.0	14.00	2.0	110	32	38	6	●
3112H7-1500	15.0	16.00	2.0	110	32	38	6	●
3112H7-1600	16.0	16.00	2.0	150	32	52	6	●
3112H7-1800	18.0	18.00	3.0	150	36	52	6	●
3112H7-2000	20.0	20.00	3.0	150	36	50	6	●



Solid Carbide Reamers  
Vollhartmetall Reibahlen

○ On demand / auf Anfrage

### Material Overview · Material Übersicht

✓ = Very suitable · Sehr empfohlen  
✓ = Suitable · Empfohlen

Grade Sorte	Workpiece material · Werkstückstoff									
	Mild steel Baustahl HB≤180	Carbon steel Alloy Steel Kohlenstoff-, Legierter Stahl	Hardened steel · Gehärteter Stahl			Stainless steel Rostfreier Stahl	Cast iron Gusseisen	Nodular cast iron GGG Kugelgra- phitguss	Aluminum alloy Aluleg.	Copper alloy Kupferleg.
~40HRC	~50HRC	~60HRC								
KRG102		✓	✓				✓	✓		

● Ex Stock / ab Lager

### 3103H7 with Straight shank and left helical flute mit Zylinderschaft und linksgedrallter Spannute

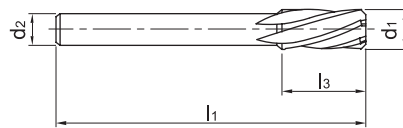

Type Typ	Basic dimension(mm) · Basis Abmessungen				Number of teeth Zähnezahl	Grade · Sorte YK10F
	d1	d2(h6)	l1	l3		
3103H7-0400	4.0	3.55	56	20	4	○
3103H7-0450	4.5	4.00	63	22	6	○
3103H7-0500	5.0	4.00	63	22	6	○
3103H7-0550	5.5	5.00	63	22	6	○
3103H7-0600	6.0	5.00	63	22	6	○
3103H7-0650	6.5	5.00	63	22	6	○
3103H7-0700	7.0	6.30	71	25	6	○
3103H7-0750	7.5	6.30	71	25	6	○
3103H7-0800	8.0	6.30	71	25	6	○
3103H7-0850	8.5	8.00	71	25	6	○
3103H7-0900	9.0	8.00	71	25	6	○
3103H7-0950	9.5	8.00	71	25	6	○
3103H7-1000	10.0	8.00	71	25	6	○
3103H7-1050	10.5	8.00	71	25	6	○
3103H7-1100	11.0	10.00	80	28	6	○
3103H7-1150	11.5	10.00	80	28	6	○
3103H7-1200	12.0	10.00	80	28	6	○
3103H7-1250	12.5	10.00	80	28	6	○
3103H7-1300	13.0	10.00	80	28	6	○
3103H7-1350	13.5	12.5	90	32	6	○
3103H7-1400	14.0	12.5	90	32	6	○
3103H7-1450	14.5	12.5	90	32	6	○
3103H7-1500	15.0	12.5	90	32	6	○
3103H7-1550	15.5	12.5	90	32	6	○
3103H7-1600	16.0	12.5	90	32	6	○
3103H7-1700	17.0	12.5	90	32	6	○
3103H7-1800	18.0	16.00	100	36	6	○
3103H7-1900	19.0	16.00	100	36	6	○
3103H7-2000	20.0	16.00	100	36	6	○

### Material Overview · Material Übersicht

✓ = Very suitable · Sehr empfohlen  
 ✓ = Suitable · Empfohlen

Grade Sorte	Workpiece material · Werkstückstoff									
	Mild steel Baustahl HB≤180	Carbon steel Alloy Steel Kohlenstoff-, Legierter Stahl	Hardened steel · Gehärteter Stahl			Stainless steel Rostfreier Stahl	Cast iron Gusseisen	Nodular cast iron GGG Kugelgra- phitguss	Aluminum alloy Aluleg.	Copper alloy Kupferleg.
YK10F			~40HRC	~50HRC	~60HRC		✓	✓	✓	✓

Code key C143  
ISO Kennzeichen

Cutting data C148  
Schnittdaten

Technical Information C149-151  
Technische Information.

Non-standart tailor made C152  
Bestellformular für Sonderwerkzeuge

○ On demand / auf Anfrage  
● Ex Stock / ab Lager



Solid Carbide Reamers  
Vollhartmetall Reibahlen

# Reaming · Reiben

Solid Carbide Reamers · Vollhartmetall-Reibahlen

3101H7 / 3102H7 / 3103H7

Workpiece material Werkstück- stoff	Cast iron Nodular cast iron GGG Gusseisen, Kugelgraphitguss			Copper alloy Kupferlegierungen			Aluminium alloy Alulegierungen		
Vc	8~16m/min			10~25m/min			15~30 m/min		
Ø (mm)	n (min <sup>-1</sup> )	f (mm/r)	Tolerance Toleranz (mm)	n (min <sup>-1</sup> )	f (mm/r)	Tolerance Toleranz (mm)	n (min <sup>-1</sup> )	f (mm/r)	Tolerance Toleranz (mm)
4	950	0.04~0.06	0.1~0.2	1600	0.04~0.06	0.1~0.2	2000	0.04~0.06	0.1~0.2
5	760	0.05~0.09	0.1~0.2	1300	0.05~0.09	0.1~0.2	1600	0.05~0.09	0.1~0.2
6	640	0.06~0.12	0.1~0.2	1050	0.06~0.12	0.1~0.2	1300	0.06~0.12	0.1~0.2
7	550	0.07~0.14	0.1~0.2	910	0.07~0.14	0.1~0.2	1150	0.07~0.14	0.1~0.2
8	480	0.08~0.16	0.1~0.2	800	0.08~0.16	0.1~0.2	1000	0.08~0.16	0.1~0.2
9	430	0.09~0.18	0.1~0.2	710	0.09~0.18	0.1~0.2	890	0.09~0.18	0.1~0.2
10	380	0.10~0.20	0.1~0.2	640	0.10~0.20	0.1~0.2	800	0.10~0.20	0.1~0.2
11	350	0.11~0.22	0.1~0.2	580	0.11~0.22	0.1~0.2	720	0.11~0.22	0.1~0.2
12	320	0.12~0.24	0.1~0.2	530	0.12~0.24	0.1~0.2	660	0.12~0.24	0.1~0.2
13	290	0.13~0.26	0.1~0.2	490	0.13~0.26	0.1~0.2	610	0.13~0.26	0.1~0.2
14	270	0.14~0.28	0.1~0.2	460	0.14~0.28	0.1~0.2	570	0.14~0.28	0.1~0.2
15	250	0.15~0.30	0.1~0.2	430	0.15~0.30	0.1~0.2	530	0.15~0.30	0.1~0.2
16	240	0.16~0.32	0.1~0.2	400	0.16~0.32	0.1~0.2	500	0.16~0.32	0.1~0.2
17	225	0.18~0.34	0.1~0.2	380	0.18~0.34	0.1~0.2	470	0.18~0.34	0.1~0.2
18	210	0.20~0.36	0.1~0.2	350	0.20~0.36	0.1~0.2	440	0.20~0.36	0.1~0.2
19	200	0.22~0.38	0.1~0.2	340	0.22~0.38	0.1~0.2	420	0.22~0.38	0.1~0.2
20	190	0.24~0.40	0.1~0.2	320	0.24~0.40	0.1~0.2	400	0.24~0.40	0.1~0.2

1. Please select the holder with high rigidity and precision.
2. Make sure supply sufficient coolant.
3. Please adjust cutting parameters according to workpiece and machine rigidity.

1. Bitte wählen Sie einen Halter mit hoher Stabilität und Genauigkeit.
2. Stellen Sie sicher, dass ausreichend Kühlmittel bereit gestellt wird.
3. Bitte stimmen Sie die Schnittdaten mit dem Werkstück und der Stabilität der Maschine ab.



Solid Carbide Reamers  
Vollhartmetall Reibahlen

# Threading · Gewinde

## Threading tools · Gewindewerkzeuge









<b>Threading tools overview</b>	<b>C155</b>	<b>Gewindewerkzeuge Übersicht</b>
<b>Graphics identification</b>	<b>C155</b>	<b>Graphische Werkzeugbeschreibung</b>
<b>Threading tools Code Key</b>	<b>C156</b>	<b>ISO Kennzeichnung</b>
<b>Detail information</b>	<b>C154-C174</b>	<b>Detaillierte Informationen</b>
Solid carbide threading tools	C157-C168	VHM Gewindeformer und Gewindebohrer
Solid carbide threading end mills	C170-C171	VHM Gewindefräser
Recommended cutting data	C172	Empfohlene Schnittdaten
<b>Technical information</b>	<b>C173</b>	<b>Technische Information</b>
Order form for non-standard products	C174	Bestellformular für Sonderwerkzeuge

# Threading · Gewindebearbeitung

Solid Carbide Taps and cutter · Vollhartmetall-Gewindebohrer, -fräser

## Threading tool overview · VHM-Gewindebohrer, -fräser Übersicht

Name	Type Typ	Shape Ausführung	Diameter range Durchmesserbereich Ø	Workpiece material Werkstückstoff								Page Seite	
				P	M	K	N	S	H	Specification Spezifikation	Cutting datas Schmittdaten		
				Carbon steel Kohlenstoff - Stahl	Alloy steel Leg. Stahl	Stainless steel Rostfreier Stahl	Cast iron Gusseisen	Aluminum alloy Alulegierung	Copper alloy Kupferlegierung			Heat resist. alloy Warmfeste Leg.	High hard. steel gehärteter Stahl
Thread forming tap Gewindeformer	4122A		M1-M2.5						✓				C157
	4222A		M3-M16						✓				C158
	4122M		M1-M2.5	✓		✓		✓					C159
	4222M		M3-M16	✓		✓		✓					C160
Helical-flute tap Spiral genutet	4201C		M3-M16				✓						C161
	4201A							✓					C165
Straight-flute tap Gerade genutet	4202C		M3-M16				✓						C163
	4202A							✓					C167
Threading end mills Gewindefräser	4111		M3-M20	✓	✓		✓	✓					C170

✓ = Very suitable · Sehr empfohlen  
 ✓ = Suitable · Empfohlen

## Graphics identification · Graphische Werkzeugbeschreibung

### Shank · Schaft



Straight shank  
Zylinderschaft



Square Straight shank as per DIN10  
DIN 10 Schaft

### Thread profile angle of tap Winkel des Gewindeprofils



Indicate 60°  
Indicate 60°

### Precision class of screw thread Präzisionsklasse des Gewindes



screw thread  
Schraubengewinde



screw thread  
Schraubengewinde



# Threading · Gewindebearbeitung

Solid Carbide Taps and cutter · Vollhartmetall-Gewindebohrer, -fräser

## Threading taps and cutter Code Key · ISO Kennzeichnung Gewindefräser, -bohrer

Tool Type Werkzeugtyp	
Code	Description · Beschreibung
4	Threading cutter Gewinde-Bearbeitungs- Werkzeug

Chip flute Spannut	
Code	Description · Beschreibung
1	Right chip flute · Spannut Rechtsdrall
2	Straight flute · Spannut gerade
3	Left chip flute · Spannut Linksdrall

material Material	
Code	Description · Beschreibung
A	Aluminum alloy Aluminumlegierung
C	Cast iron Grauguss
M	Stainless steel Rostfreier Stahl
P	Carbon steel Kohlenstoff - Stahl
H	High hard. steel gehärteter Stahl

**4 2 0 1 A C S -M5x0.5 -6H**

Shank Schaftausführung	
Code	Description · Beschreibung
1	Straight shank / Zylinderschaft
2	Square Straight shank as per DIN10 Zylinderschaft DIN10
5	Straight shank as per DIN 6535HA Zylinderschaft DIN 6535HA
9	Tapered shank Konischer Schaft

Cooling Kühlung	
Code	Description · Beschreibung
Default Standard	Extern · Extern
C	Intern · Intern

Specification Spezifikation	
Code	Description · Beschreibung
M5	Nominal diameter of standard threading cutters is M5 Der angegebene Durchmesser ist M 5
0.5	Pitch Steigung

Typ of function Art der Bearbeitung	
Code	Description · Beschreibung
0	Tap Gewindebohrer
1	Thread milling cutter Gewindefräser
2	Thread forming tap Gewindeformer

Hole shape Bohrungsausführung	
Code	Description · Beschreibung
Default Standard	Through-hole Durchgangsbohrung
S	Blind-hole Sackbohrung

Precision class Präzisionsklasse	
Code	Description · Beschreibung
6H	ISO metric thread ISO metrische Gewinde
6HX	General pitch thread "General pitch" Gewinde

**C**

Solid Carbide drills  
Vollhartmetallbohrer

# Threading · Gewindebearbeitung

Solid Carbide Taps and cutter · Vollhartmetall-Gewindebohrer, -fräser

**4122A**  
**4222A**

Thread forming tap for aluminum alloy machining  
Gewindeformer zur Bearbeitung von Aluminiumlegierungen

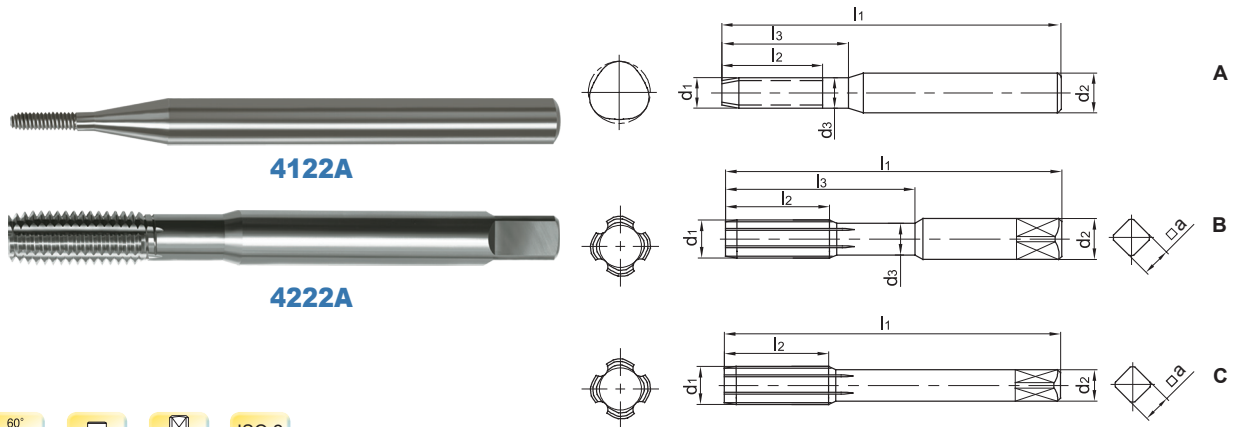

Type Typ	Cooling Kühlung	Basic dimension(mm) Basis Abmessungen											Number of teeth Zähne- anzahl	Grade Sorte YK40F	Coredrill Kernbohr d	
		Taper length Anschlitt- länge	d <sub>1</sub>	P	d <sub>2</sub>	d <sub>3</sub>	l <sub>1</sub>	l <sub>2</sub>	l <sub>3</sub>	a×a	Thread- profile Gewinde- profil	Geometry Ausführung				
4122A-M1*0.25-6H	Extern	3P	M1	0.25	3		40	5				60°	A	3	●	0.9
4122AS-M1*0.25-6H	Extern	1.5P	M1	0.25	3		40	5				60°	A	3	●	0.9
4122A-M1.2*0.25-6H	Extern	3P	M1.2	0.25	3		40	5				60°	A	3	●	1.1
4122AS-M1.2*0.25-6H	Extern	1.5P	M1.2	0.25	3		40	5				60°	A	3	●	1.1
4122A-M1.6*0.35-6H	Extern	3P	M1.6	0.35	3	1.1	40	5	11			60°	A	3	●	1.47
4122AS-M1.6*0.35-6H	Extern	1.5P	M1.6	0.35	3	1.1	40	5	11			60°	A	3	●	1.47
4122A-M2*0.4-6H	Extern	3P	M2	0.4	3	1.5	45	6	12			60°	A	3	●	1.85
4122AS-M2*0.4-6H	Extern	1.5P	M2	0.4	3	1.5	45	6	12			60°	A	3	●	1.85
4122A-M2.5*0.45-6H	Extern	3P	M2.5	0.45	3	1.9	50	6	14			60°	A	3	●	2.33
4122AS-M2.5*0.45-6H	Extern	1.5P	M2.5	0.45	3	1.9	50	6	14			60°	A	3	●	2.33
4222A-M3*0.5-6H	Extern	3P	M3	0.5	3.5	2.3	56	6	18	2.7		60°	B	4	●	2.8
4222AS-M3*0.5-6H	Extern	1.5P														
4222A-M4*0.5-6H	Extern	3P	M4	0.5	4.5	3.1	63	8	21	3.4		60°	B	4	●	3.8
4222AS-M4*0.5-6H	Extern	1.5P														
4222A-M4*0.7-6H	Extern	3P	M4	0.7	4.5	3.1	63	8	21	3.4		60°	B	4	●	3.7
4222AS-M4*0.7-6H	Extern	1.5P														
4222A-M5*0.5-6H	Extern	3P	M5	0.5	6	4.3	70	10	25	4.9		60°	B	4	●	4.8
4222AS-M5*0.5-6H	Extern	1.5P														
4222A-M5*0.8-6H	Extern	3P	M5	0.8	6	4	70	10	25	4.9		60°	B	4	●	4.65
4222AS-M5*0.8-6H	Extern	1.5P														
4222A-M6*0.75-6H	Extern	3P	M6	0.75	6	5	80	12	30	4.9		60°	B	4	●	5.7
4222AS-M6*0.75-6H	Extern	1.5P														
4222A-M6*1-6H	Extern	3P	M6	1	6	4.7	80	12	30	4.9		60°	B	4	●	5.6
4222AS-M6*1-6H	Extern	1.5P														
4222A-M7*1-6H	Extern	3P	M7	1	7	5.7	80	14	30	5.5		60°	B	4	●	6.6
4222AS-M7*1-6H	Extern	1.5P														



Solid Carbide drills  
Vollhartmetallbohrer

# Threading · Gewindebearbeitung

Solid Carbide Taps and cutter · Vollhartmetall-Gewindebohrer, -fräser

Type Typ	Cooling Kühlung	Taper length Anschnitt- länge	Basic dimension(mm) Basis Abmessungen										Number of teeth Zähne- anzahl	Grade Sorte	Coredrill Kernbohr
			d1	P	d2	d3	l1	l2	l3	a×a	Thread- profile Gewinde- profil	Geometry Ausführung		YK40F	
4222A-M8*1-6H	Extern	3P	M8	1	8	6.7	90	16	35	6.2	60°	B	4	●	7.6
4222AS-M8*1-6H	Extern	1.5P													
4222A-M8*1.25-6H	Extern	3P	M8	1.25	8	6.4	90	16	35	6.2	60°	B	4	●	7.45
4222AS-M8*1.25-6H	Extern	1.5P													
4222A-M10*1-6H	Extern	3P	M10	1	10	8.7	100	20	39	8	60°	B	5	●	9.6
4222AS-M10*1-6H	Extern	1.5P													
4222A-M10*1.25-6H	Extern	3P	M10	1.25	10	8.4	100	20	39	8	60°	B	5	●	9.45
4222AS-M10*1.25-6H	Extern	1.5P													
4222A-M10*1.5-6H	Extern	3P	M10	1.5	10	8.1	100	20	39	8	60°	B	5	●	9.35
4222AS-M10*1.5-6H	Extern	1.5P													
4222AC-M10*1.5-6H	Intern	3P	M10	1.5	10	8.1	100	20	39	8	60°	B	5	●	9.35
4222ACS-M10*1.5-6H	Intern	1.5P													
4222A-M12*1.25-6H	Extern	3P	M12	1.25	9		110	24		7	60°	C	5	●	11.45
4222AS-M12*1.25-6H	Extern	1.5P													
4222A-M12*1.5-6H	Extern	3P	M12	1.5	9		110	24		7	60°	C	5	●	11.35
4222AS-M12*1.5-6H	Extern	1.5P													
4222A-M12*1.75-6H	Extern	3P	M12	1.75	9		110	24		7	60°	C	5	●	11.25
4222AS-M12*1.75-6H	Extern	1.5P													
4222AC-M12*1.75-6H	Intern	3P	M12	1.75	9		110	24		7	60°	C	5	●	11.25
4222ACS-M12*1.75-6H	Intern	1.5P													
4222A-M14*1.5-6H	Extern	3P	M14	1.5	11		110	26		9	60°	C	6	●	13.35
4222AS-M14*1.5-6H	Extern	1.5P													
4222A-M14*2-6H	Extern	3P	M14	2	11		110	26		9	60°	C	6	●	13.1
4222AS-M14*2-6H	Extern	1.5P													
4222A-M16*1.5-6H	Extern	3P	M16	1.5	12		110	27		9	60°	C	6	●	15.35
4222AS-M16*1.5-6H	Extern	1.5P													
4222A-M16*2-6H	Extern	3P	M16	2	12		110	27		9	60°	C	6	●	15.1
4222AS-M16*2-6H	Extern	1.5P													
4222AC-M16*2-6H	Intern	3P	M16	2	12		110	27		9	60°	C	6	●	15.1
4222ACS-M16*2-6H	Intern	1.5P													

## Material Overview · Material Übersicht

✓ = Very suitable · Sehr empfohlen  
 ✓ = Suitable · Empfohlen

Grade Sorte	Workpiece material · Werkstückstoff									
	Mild steel Baustahl HB≤180	Carbon steel Alloy Steel Kohlenstoff- Legierter Stahl	Hardened steel · Gehärteter Stahl			Stainless steel Rostfreier Stahl	Cast iron Gusseisen	Nodular cast iron GGG Kugelgra- phitguss	Aluminum alloy Aluleg.	Copper alloy Kupferleg.
YK40F			~40HRC	~50HRC	~60HRC				✓	

Code key C 156  
ISO Kennzeichen

Cutting data C172  
Schnittdaten

Technical Information C173-174  
Technische Information.

Non-standard tailor made C175  
Bestellformular für Sonderwerkzeuge

# Threading · Gewindebearbeitung

Solid Carbide Taps and cutter · Vollhartmetall-Gewindebohrer, -fräser

**4122M**  
**4222M**

Thread forming tap for stainless steel machining  
Gewindeformer zur Bearbeitung von Rostfreier

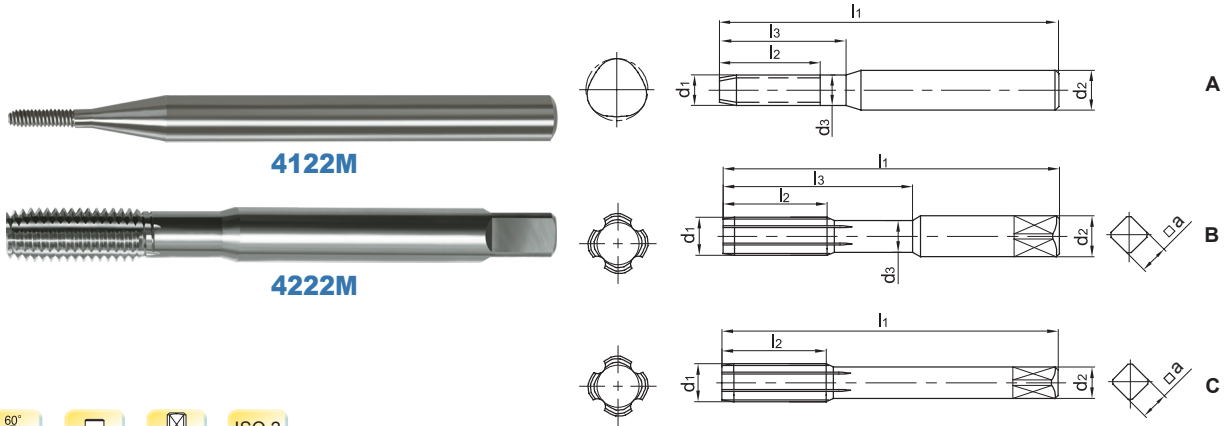

Type Typ	Cooling Kühlung	Basic dimension(mm) Basis Abmessungen											Number of teeth Zähne- anzahl	Grade Sorte		Coredrill Kernbohr	
		Taper length Anschritt- länge	d <sub>1</sub>	P	d <sub>2</sub>	d <sub>3</sub>	l <sub>1</sub>	l <sub>2</sub>	l <sub>3</sub>	a x a	Thread- profile Gewinde- profil	Geometry Ausführung		KTG402	YK40F		d
4122M-M1*0.25-6H	Extern	3P	M1	0.25	3		40	5				60°	A	4	●	○	0.9
4122MS-M1*0.25-6H	Extern	2P	M1	0.25	3		40	5				60°	A	4	●	○	0.9
4122M-M1.2*0.25-6H	Extern	3P	M1.2	0.25	3		40	5				60°	A	4	●	○	1.1
4122MS-M1.2*0.25-6H	Extern	2P	M1.2	0.25	3		40	5				60°	A	4	●	○	1.1
4122M-M1.6*0.35-6H	Extern	3P	M1.6	0.35	3	1.1	40	5	11			60°	A	4	●	○	1.47
4122MS-M1.6*0.35-6H	Extern	2P	M1.6	0.35	3	1.1	40	5	11			60°	A	4	●	○	1.47
4122M-M2*0.4-6H	Extern	3P	M2	0.4	3	1.5	45	6	12			60°	A	4	●	○	1.85
4122MS-M2*0.4-6H	Extern	2P	M2	0.4	3	1.5	45	6	12			60°	A	4	●	○	1.85
4122M-M2.5*0.45-6H	Extern	3P	M2.5	0.45	3	1.9	50	6	14			60°	A	4	●	○	2.33
4122MS-M2.5*0.45-6H	Extern	2P	M2.5	0.45	3	1.9	50	6	14			60°	A	4	●	○	2.33
4222M-M3*0.5-6H	Extern	3P	M3	0.5	3.5	2.3	56	6	18	2.7		60°	B	4	●	○	2.8
4222MS-M3*0.5-6H	Extern	2P	M3	0.5	3.5	2.3	56	6	18	2.7		60°	B	4	●	○	2.8
4222M-M4*0.5-6H	Extern	3P	M4	0.5	4.5	3.1	63	8	21	3.4		60°	B	4	●	○	3.8
4222MS-M4*0.5-6H	Extern	2P	M4	0.5	4.5	3.1	63	8	21	3.4		60°	B	4	●	○	3.8
4222M-M4*0.7-6H	Extern	3P	M4	0.7	4.5	3.1	63	8	21	3.4		60°	B	4	●	○	3.7
4222MS-M4*0.7-6H	Extern	2P	M4	0.7	4.5	3.1	63	8	21	3.4		60°	B	4	●	○	3.7
4222M-M5*0.5-6H	Extern	3P	M5	0.5	6	4.3	70	10	25	4.9		60°	B	4	●	○	4.8
4222MS-M5*0.5-6H	Extern	2P	M5	0.5	6	4.3	70	10	25	4.9		60°	B	4	●	○	4.8
4222M-M5*0.8-6H	Extern	3P	M5	0.8	6	4	70	10	25	4.9		60°	B	4	●	○	4.65
4222MS-M5*0.8-6H	Extern	2P	M5	0.8	6	4	70	10	25	4.9		60°	B	4	●	○	4.65
4222M-M6*0.75-6H	Extern	3P	M6	0.75	6	5	80	12	30	4.9		60°	B	4	●	○	5.7
4222MS-M6*0.75-6H	Extern	2P	M6	0.75	6	5	80	12	30	4.9		60°	B	4	●	○	5.7
4222M-M6*1-6H	Extern	3P	M6	1	6	4.7	80	12	30	4.9		60°	B	4	●	○	5.6
4222MS-M6*1-6H	Extern	2P	M6	1	6	4.7	80	12	30	4.9		60°	B	4	●	○	5.6
4222M-M7*1-6H	Extern	3P	M7	1	7	5.7	80	14	30	5.5		60°	B	4	●	○	6.6
4222MS-M7*1-6H	Extern	2P	M7	1	7	5.7	80	14	30	5.5		60°	B	4	●	○	6.6

**C**

Solid Carbide drills  
Vollhartmetallbohrer

# Threading · Gewindebearbeitung

Solid Carbide Taps and cutter · Vollhartmetall-Gewindebohrer, -fräser

Type Typ	Cooling Kühlung	Taper length Anschrittlänge	Basic dimension(mm) Basis Abmessungen										Number of teeth Zahneanzahl	Grade Sorte		Coredrill Kernbohr
			d <sub>1</sub>	P	d <sub>2</sub>	d <sub>3</sub>	l <sub>1</sub>	l <sub>2</sub>	l <sub>3</sub>	a×a	Thread profile Gewindeprofil	Geometry Ausführung		KTG402	YK40F	
4222M-M8*1-6H	Extern	3P	M8	1	8	6.7	90	16	35	6.2	60°	B	4	●	○	7.6
4222MS-M8*1-6H	Extern	2P														
4222M-M8*1.25-6H	Extern	3P	M8	1.25	8	6.4	90	16	35	6.2	60°	B	4	●	○	7.45
4222MS-M8*1.25-6H	Extern	2P														
4222M-M10*1-6H	Extern	3P	M10	1	10	8.7	100	20	39	8	60°	B	5	●	○	9.6
4222MS-M10*1-6H	Extern	2P														
4222M-M10*1.25-6H	Extern	3P	M10	1.25	10	8.4	100	20	39	8	60°	B	5	●	○	9.45
4222MS-M10*1.25-6H	Extern	2P														
4222M-M10*1.5-6H	Extern	3P	M10	1.5	10	8.1	100	20	39	8	60°	B	5	●	○	9.35
4222MS-M10*1.5-6H	Extern	2P														
4222MC-M10*1.5-6H	Intern	3P														
4222MCS-M10*1.5-6H	Intern	2P														
4222M-M12*1.25-6H	Extern	3P	M12	1.25	9		110	24		7	60°	C	5	●	○	11.45
4222MS-M12*1.25-6H	Extern	2P														
4222M-M12*1.5-6H	Extern	3P	M12	1.5	9		110	24		7	60°	C	5	●	○	11.35
4222MS-M12*1.5-6H	Extern	2P														
4222M-M12*1.75-6H	Extern	3P	M12	1.75	9		110	24		7	60°	C	5	●	○	11.25
4222MS-M12*1.75-6H	Extern	2P														
4222MC-M12*1.75-6H	Intern	3P														
4222MCS-M12*1.75-6H	Intern	2P														
4222M-M14*1.5-6H	Extern	3P	M14	1.5	11		110	26		9	60°	C	6	●	○	13.35
4222MS-M14*1.5-6H	Extern	2P														
4222M-M14*2-6H	Extern	3P	M14	2	11		110	26		9	60°	C	6	●	○	13.1
4222MS-M14*2-6H	Extern	2P														
4222M-M16*1.5-6H	Extern	3P	M16	1.5	12		110	27		9	60°	C	6	●	○	15.35
4222MS-M16*1.5-6H	Extern	2P														
4222M-M16*2-6H	Extern	3P	M16	2	12		110	27		9	60°	C	6	●	○	15.1
4222MS-M16*2-6H	Extern	2P														
4222MC-M16*2-6H	Intern	3P														
4222MCS-M16*2-6H	Intern	2P														

## Material Overview · Material Übersicht

✓ = Very suitable · Sehr empfohlen  
 ✓ = Suitable · Empfohlen

Grade Sorte	Workpiece material · Werkstückstoff									
	Mild steel Baustahl HB≤180	Carbon steel Alloy Steel Kohlenstoff- Legierter Stahl	Hardened steel · Gehärteter Stahl			Stainless steel Rostfreier Stahl	Cast iron Gusseisen	Nodular cast iron GGG Kugelgra- phitguss	Aluminum alloy Aluleg.	Copper alloy Kupferleg.
KTG402	✓					✓				
YK40F	✓					✓		✓		

Code key C 156  
ISO Kennzeichen

Cutting data C172  
Schnittdaten

Technical Information C173-174  
Technische Information.

Non-standard tailor made C175  
Bestellformular für Sonderwerkzeuge

# Threading · Gewindebearbeitung

Solid Carbide Taps and cutter · Vollhartmetall-Gewindebohrer, -fräser

## 4201C

Tap for cast iron machining  
Gewindebohrer zur Bearbeitung von Grauguss

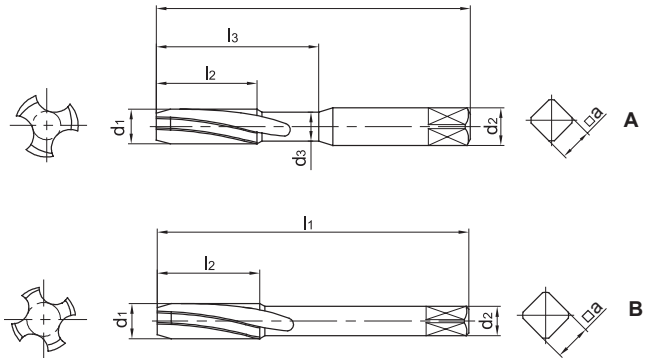

Type Typ	Taper length Anschrittlänge	Basic dimension(mm) Basis Abmessungen										Number of teeth Zähnezahl	Grade Sorte YK40F	Coredrill Kernbohr d
		d1	P	d2	d3	l1	l2	l3	a×a	Thread-profile Gewindeprofil	Geometry Ausführung			
4201C-M3*0.5-6H	3P	M3	0.5	3.5	2.3	56	11	18	2.7	60°	A	3	●	2.5
4201C-M3*0.5-6HX	3P													
4201CS-M3*0.5-6H	1.5P													
4201CS-M3*0.5-6HX	1.5P													
4201C-M4*0.7-6H	3P	M4	0.7	4.5	3.1	63	13	21	3.4	60°	A	3	●	3.3
4201C-M4*0.7-6HX	3P													
4201CS-M4*0.7-6H	1.5P													
4201CS-M4*0.7-6HX	1.5P													
4201C-M5*0.8-6H	3P	M5	0.8	6	4	70	16	25	4.9	60°	A	3	●	4.2
4201C-M5*0.8-6HX	3P													
4201CS-M5*0.8-6H	1.5P													
4201CS-M5*0.8-6HX	1.5P													
4201C-M6*0.75-6H	3P	M6	0.75	6	5	80	19	30	4.9	60°	A	3	●	5.25
4201C-M6*0.75-6HX	3P													
4201CS-M6*0.75-6H	1.5P													
4201CS-M6*0.75-6HX	1.5P													
4201C-M6*1-6H	3P	M6	1	6	4.7	80	19	30	4.9	60°	A	3	●	5
4201CC-M6*1-6H	3P													
4201C-M6*1-6HX	3P													
4201CS-M6*1-6H	1.5P													
4201CCS-M6*1-6H	1.5P													
4201CS-M6*1-6HX	1.5P													
4201C-M7*1-6H	3P	M7	1	7	5.7	80	19	30	5.5	60°	A	3	●	6
4201CS-M7*1-6H	1.5P													
4201C-M8*1-6H	3P	M8	1.25	8	6.4	90	22	35	6.2	60°	A	3	●	6.75
4201CS-M8*1-6H	1.5P													
4201C-M8*1.25-6H	3P													
4201CC-M8*1.25-6H	3P													
4201C-M8*1.25-6HX	3P													
4201CS-M8*1.25-6H	1.5P													
4201CCS-M8*1.25-6H	1.5P													
4201CS-M8*1.25-6HX	1.5P													

**C**

Solid Carbide drills  
Vollhartmetallbohrer

# Threading · Gewindebearbeitung

Solid Carbide Taps and cutter · Vollhartmetall-Gewindebohrer, -fräser

Type Typ	Taper length Anschnitt- länge	Basic dimension(mm) Basis Abmessungen										Number of teeth Zähne- anzahl	Grade Sorte	Coredrill Kernbohr
		d <sub>1</sub>	P	d <sub>2</sub>	d <sub>3</sub>	l <sub>1</sub>	l <sub>2</sub>	l <sub>3</sub>	a×a	Thread- profile Gewinde- profil	Geometry Ausführung		YK40F	d
4201C-M10*1-6H	3P	M10	1	10	8.7	100	20	39	8	60°	A	4	●	9
4201CS-M10*1-6H	1.5P													
4201C-M10*1.25-6H	3P	M10	1.25	10	8.4	100	24	39	8	60°	A	4	●	8.75
4201CS-M10*1.25-6H	1.5P													
4201C-M10*1.5-6H	3P	M10	1.5	10	8.1	100	24	39	8	60°	A	4	●	8.5
4201CC-M10*1.5-6H	3P													
4201C-M10*1.5-6HX	3P													
4201CS-M10*1.5-6H	1.5P													
4201CCS-M10*1.5-6H	1.5P													
4201CS-M10*1.5-6HX	1.5P													
4201C-M12*1.25-6H	3P	M12	1.25	9		110	29		7	60°	B	4	●	10.75
4201CS-M12*1.25-6H	1.5P													
4201C-M12*1.5-6H	3P	M12	1.5	9		110	29		7	60°	B	4	●	10.5
4201CS-M12*1.5-6H	1.5P													
4201C-M12*1.75-6H	3P	M12	1.75	9		110	29		7	60°	B	4	●	10.25
4201CC-M12*1.75-6H	3P													
4201C-M12*1.75-6HX	3P													
4201CS-M12*1.75-6H	1.5P													
4201CCS-M12*1.75-6H	1.5P													
4201CS-M12*1.75-6HX	1.5P													
4201C-M14*1.5-6H	3P	M14	1.5	11		110	30		9	60°	B	4	●	12.5
4201CS-M14*1.5-6H	1.5P													
4201C-M14*2-6H	3P	M14	2	11		110	30		9	60°	B	4	●	12
4201CS-M14*2-6H	1.5P													
4201C-M16*1.5-6H	3P	M16	1.5	12		110	32		9	60°	B	4	●	14.5
4201CS-M16*1.5-6H	1.5P													
4201C-M16*2-6H	3P	M16	2	12		110	32		9	60°	B	4	●	14
4201C-M16*2-6HX	3P													
4201CS-M16*2-6H	1.5P													
4201CS-M16*2-6HX	1.5P													

## Material Overview · Material Übersicht

✓ = Very suitable · Sehr empfohlen  
 ✓ = Suitable · Empfohlen

Grade Sorte	Workpiece material · Werkstückstoff									
	Mild steel Baustahl HB≤180	Carbon steel Alloy Steel Kohlenstoff-, Legierter Stahl	Hardened steel · Gehärteter Stahl			Stainless steel Rostfreier Stahl	Cast iron Gusseisen	Nodular cast iron GGG Kugelgra- phitguss	Aluminum alloy Aluleg.	Copper alloy Kupferleg.
YK40F			~40HRC	~50HRC	~60HRC		✓	✓		

Code key C 156  
ISO Kennzeichen

Cutting data C172  
Schnittdaten

Technical Information C173-174  
Technische Information.

Non-standard tailor made C175  
Bestellformular für Sonderwerkzeuge

# Threading · Gewindebearbeitung

Solid Carbide Taps and cutter · Vollhartmetall-Gewindebohrer, -fräser

## 4202C

Tap for cast iron machining

Gewindebohrer zur Bearbeitung von Grauguss

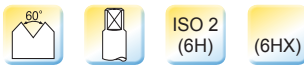
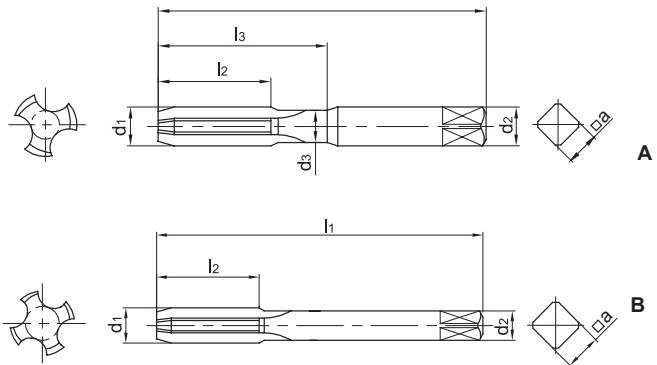

Type Typ	Taper length Anschlitt- länge	Basic dimension(mm) Basis Abmessungen										Number of teeth Zähne- anzahl	Grade Sorte YK40F	Coredrill Kernbohr d
		d <sub>1</sub>	P	d <sub>2</sub>	d <sub>3</sub>	l <sub>1</sub>	l <sub>2</sub>	l <sub>3</sub>	a×a	Thread- profile Gewinde- profil	Geometry Ausführung			
4202C-M3*0.5-6H	3P	M3	0.5	3.5	2.3	56	11	18	2.7	60°	A	3	●	2.5
4202C-M3*0.5-6HX	3P													
4202CS-M3*0.5-6H	1.5P													
4202CS-M3*0.5-6HX	1.5P													
4202C-M4*0.7-6H	3P	M4	0.7	4.5	3.1	63	13	21	3.4	60°	A	3	●	3.3
4202C-M4*0.7-6HX	3P													
4202CS-M4*0.7-6H	1.5P													
4202CS-M4*0.7-6HX	1.5P													
4202C-M5*0.8-6H	3P	M5	0.8	6	4	70	16	25	4.9	60°	A	3	●	4.2
4202C-M5*0.8-6HX	3P													
4202CS-M5*0.8-6H	1.5P													
4202CS-M5*0.8-6HX	1.5P													
4202C-M6*0.75-6H	3P	M6	0.75	6	5	80	19	30	4.9	60°	A	3	●	5.25
4202C-M6*0.75-6HX	3P													
4202CS-M6*0.75-6H	1.5P													
4202CS-M6*0.75-6HX	1.5P													
4202C-M6*1-6H	3P	M6	1	6	4.7	80	19	30	4.9	60°	A	3	●	5
4202CC-M6*1-6H	3P													
4202C-M6*1-6HX	3P													
4202CS-M6*1-6H	1.5P													
4202CCS-M6*1-6H	1.5P													
4202CS-M6*1-6HX	1.5P													
4202C-M7*1-6H	3P	M7	1	7	5.7	80	19	30	5.5	60°	A	3	●	6
4202CS-M7*1-6H	1.5P													
4202C-M8*1-6H	3P	M8	1	8	6.7	90	20	35	6.2	60°	A	3	●	7
4202CS-M8*1-6H	1.5P													
4202C-M8*1.25-6H	3P													
4202CC-M8*1.25-6H	3P	M8	1.25	8	6.4	90	22	35	6.2	60°	A	3	●	6.75
4202C-M8*1.25-6HX	3P													
4202CS-M8*1.25-6H	1.5P													
4202CCS-M8*1.25-6H	1.5P													
4202CS-M8*1.25-6HX	1.5P													



Solid Carbide drills  
Vollhartmetallbohrer

# Threading · Gewindebearbeitung

Solid Carbide Taps and cutter · Vollhartmetall-Gewindebohrer, -fräser

Type Typ	Basic dimension(mm) Basis Abmessungen											Number of teeth Zähne- anzahl	Grade Sorte  YK40F	Coredrill Kernbohr  d
	Taper length Anschnit- länge	d <sub>1</sub>	P	d <sub>2</sub>	d <sub>3</sub>	l <sub>1</sub>	l <sub>2</sub>	l <sub>3</sub>	a×a	Thread- profile Gewinde- profil	Geometry Ausführung			
4202C-M10*1-6H	3P	M10	1	10	8.7	100	20	39	8	60°	A	4	●	9
4202CS-M10*1-6H	1.5P													
4202C-M10*1.25-6H	3P	M10	1.25	10	8.4	100	24	39	8	60°	A	4	●	8.75
4202CS-M10*1.25-6H	1.5P													
4202C-M10*1.5-6H	3P	M10	1.5	10	8.1	100	24	39	8	60°	A	4	●	8.5
4202CC-M10*1.5-6H	3P													
4202C-M10*1.5-6HX	3P													
4202CS-M10*1.5-6H	1.5P													
4202CCS-M10*1.5-6H	1.5P													
4202CS-M10*1.5-6HX	1.5P													
4202C-M12*1.25-6H	3P	M12	1.25	9		110	29		7	60°	B	4	●	10.75
4202CS-M12*1.25-6H	1.5P													
4202C-M12*1.5-6H	3P	M12	1.5	9		110	29		7	60°	B	4	●	10.5
4202CS-M12*1.5-6H	1.5P													
4202C-M12*1.75-6H	3P	M12	1.75	9		110	29		7	60°	B	4	●	10.25
4202CC-M12*1.75-6H	3P													
4202C-M12*1.75-6HX	3P													
4202CS-M12*1.75-6H	1.5P													
4202CCS-M12*1.75-6H	1.5P													
4202CS-M12*1.75-6HX	1.5P													
4202C-M14*1.5-6H	3P	M14	1.5	11		110	30		9	60°	B	4	●	12.5
4202CS-M14*1.5-6H	1.5P													
4202C-M14*2-6H	3P	M14	2	11		110	30		9	60°	B	4	●	12
4202CS-M14*2-6H	1.5P													
4202C-M16*1.5-6H	3P	M16	1.5	12		110	32		9	60°	B	4	●	14.5
4202CS-M16*1.5-6H	1.5P													
4202C-M16*2-6H	3P	M16	2	12		110	32		9	60°	B	4	●	14
4202C-M16*2-6HX	3P													
4202CS-M16*2-6H	1.5P													
4202CS-M16*2-6HX	1.5P													

## Material Overview · Material Übersicht

✓ = Very suitable · Sehr empfohlen  
 ✓ = Suitable · Empfohlen

Grade Sorte	Workpiece material · Werkstückstoff									
	Mild steel Baustahl HB≤180	Carbon steel Alloy Steel Kohlenstoff- Legierter Stahl	Hardened steel · Gehärteter Stahl			Stainless steel Rostfreier Stahl	Cast iron Gusseisen	Nodular cast iron GGG Kugelgra- phitguss	Aluminum alloy Aluleg.	Copper alloy Kupferleg.
YK40F			~40HRC	~50HRC	~60HRC		✓	✓		

Code key C 156  
ISO Kennzeichen

Cutting data C172  
Schnittdaten

Technical Information C173-174  
Technische Information.

Non-standard tailor made C175  
Bestellformular für Sonderwerkzeuge

# Threading - Gewindebearbeitung

Solid Carbide Taps and cutter - Vollhartmetall-Gewindebohrer, -fräser

## 4201A

Tap for aluminum alloy machining

Gewindebohrer zur Bearbeitung von Aluminiumlegierungen

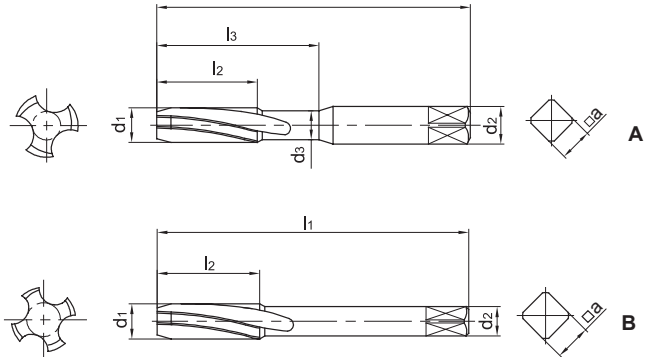

Type Typ	Basic dimension(mm) Basis Abmessungen											Number of teeth Zähneanzahl	Grade Sorte YK40F	Coredrill Kernbohr d
	Taper length Anschnittlänge	d <sub>1</sub>	P	d <sub>2</sub>	d <sub>3</sub>	l <sub>1</sub>	l <sub>2</sub>	l <sub>3</sub>	a×a	Thread-profile Gewindeprofil	Geometry Ausführung			
4201A-M3*0.5-6H	3P	M3	0.5	3.5	2.3	56	11	18	2.7	60°	A	3	●	2.5
4201A-M3*0.5-6HX	3P													
4201AS-M3*0.5-6H	1.5P	M3	0.5	3.5	2.3	56	11	18	2.7	60°	A	3	●	2.5
4201AS-M3*0.5-6HX	1.5P													
4201A-M4*0.7-6H	3P	M4	0.7	4.5	3.1	63	13	21	3.4	60°	A	3	●	3.3
4201A-M4*0.7-6HX	3P													
4201AS-M4*0.7-6H	1.5P	M4	0.7	4.5	3.1	63	13	21	3.4	60°	A	3	●	3.3
4201AS-M4*0.7-6HX	1.5P													
4201A-M5*0.8-6H	3P	M5	0.8	6	4	70	16	25	4.9	60°	A	3	●	4.2
4201A-M5*0.8-6HX	3P													
4201AS-M5*0.8-6H	1.5P	M5	0.8	6	4	70	16	25	4.9	60°	A	3	●	4.2
4201AS-M5*0.8-6HX	1.5P													
4201A-M6*0.75-6H	3P	M6	0.75	6	5	80	19	30	4.9	60°	A	3	●	5.25
4201A-M6*0.75-6HX	3P													
4201AS-M6*0.75-6H	1.5P	M6	0.75	6	5	80	19	30	4.9	60°	A	3	●	5.25
4201AS-M6*0.75-6HX	1.5P													
4201A-M6*1-6H	3P	M6	1	6	4.7	80	19	30	4.9	60°	A	3	●	5
4201AC-M6*1-6H	3P													
4201A-M6*1-6HX	3P	M6	1	6	4.7	80	19	30	4.9	60°	A	3	●	5
4201AS-M6*1-6H	1.5P													
4201ACS-M6*1-6H	1.5P	M6	1	6	4.7	80	19	30	4.9	60°	A	3	●	5
4201AS-M6*1-6HX	1.5P													
4201A-M7*1-6H	3P	M7	1	7	5.7	80	19	30	5.5	60°	A	3	●	6
4201AS-M7*1-6H	1.5P													
4201A-M8*1-6H	3P	M8	1	8	6.7	90	20	35	6.2	60°	A	3	●	7
4201AS-M8*1-6H	1.5P													

C

Solid Carbide drills  
Vollhartmetallbohrer

# Threading · Gewindebearbeitung

Solid Carbide Taps and cutter · Vollhartmetall-Gewindebohrer, -fräser

Type Typ	Taper length Anschnittlänge	Basic dimension(mm) Basis Abmessungen										Number of teeth Zähnezanzahl	Grade Sorte	Coredrill Kernbohr
		d1	P	d2	d3	l1	l2	l3	a×a	Thread-profile Gewindeprofil	Geometry Ausführung		YK40F	
4201A-M8*1.25-6H	3P	M8	1.25	8	6.4	90	22	35	6.2	60°	A	3	●	6.75
4201AC-M8*1.25-6H	3P													
4201A-M8*1.25-6HX	3P													
4201AS-M8*1.25-6H	1.5P													
4201ACS-M8*1.25-6H	1.5P													
4201AS-M8*1.25-6HX	1.5P													
4201A-M10*1-6H	3P	M10	1	10	8.7	100	20	39	8	60°	A	4	●	9
4201AS-M10*1-6H	1.5P													
4201A-M10*1.25-6H	3P	M10	1.25	10	8.4	100	24	39	8	60°	A	4	●	8.75
4201AS-M10*1.25-6H	1.5P													
4201A-M10*1.5-6H	3P	M10	1.5	10	8.1	100	24	39	8	60°	A	4	●	8.5
4201AC-M10*1.5-6H	3P													
4201A-M10*1.5-6HX	3P													
4201AS-M10*1.5-6H	1.5P													
4201ACS-M10*1.5-6H	1.5P													
4201AS-M10*1.5-6HX	1.5P													
4201A-M12*1.25-6H	3P	M12	1.25	9	110	29	7	60°	B	4	●	10.75		
4201AS-M12*1.25-6H	1.5P													
4201A-M12*1.5-6H	3P	M12	1.5	9	110	29	7	60°	B	4	●	10.5		
4201AS-M12*1.5-6H	1.5P													
4201A-M12*1.75-6H	3P	M12	1.75	9	110	29	7	60°	B	4	●	10.25		
4201AC-M12*1.75-6H	3P													
4201A-M12*1.75-6HX	3P													
4201AS-M12*1.75-6H	1.5P													
4201ACS-M12*1.75-6H	1.5P													
4201AS-M12*1.75-6HX	1.5P													
4201A-M14*1.5-6H	3P	M14	1.5	11	110	30	9	60°	B	4	●	12.5		
4201AS-M14*1.5-6H	1.5P													
4201A-M14*2-6H	3P	M14	2	11	110	30	9	60°	B	4	●	12		
4201AS-M14*2-6H	1.5P													
4201A-M16*1.5-6H	3P	M16	1.5	12	110	32	9	60°	B	4	●	14.5		
4201AS-M16*1.5-6H	1.5P													
4201A-M16*2-6H	3P	M16	2	12	110	32	9	60°	B	4	●	14		
4201A-M16*2-6HX	3P													
4201AS-M16*2-6H	1.5P													
4201AS-M16*2-6HX	1.5P													

## Material Overview · Material Übersicht

✓ = Very suitable · Sehr empfohlen  
 ✓ = Suitable · Empfohlen

Grade Sorte	Workpiece material · Werkstückstoff									
	Mild steel Baustahl HB≤180	Carbon steel Alloy Steel Kohlenstoff-, Legierter Stahl	Hardened steel · Gehärteter Stahl			Stainless steel Rostfreier Stahl	Cast iron Gusseisen	Nodular cast iron GGG Kugelgraphitguss	Aluminum alloy Aluleg.	Copper alloy Kupferleg.
YK40F									✓	

Code key C 156  
ISO Kennzeichen

Cutting data C172  
Schnittdaten

Technical Information C173-174  
Technische Information.

Non-standard tailor made C175  
Bestellformular für Sonderwerkzeuge

# Threading · Gewindebearbeitung

Solid Carbide Taps and cutter · Vollhartmetall-Gewindebohrer, -fräser

## 4202A

Tap for aluminum alloy machining

Gewindebohrer zur Bearbeitung von Aluminiumlegierungen

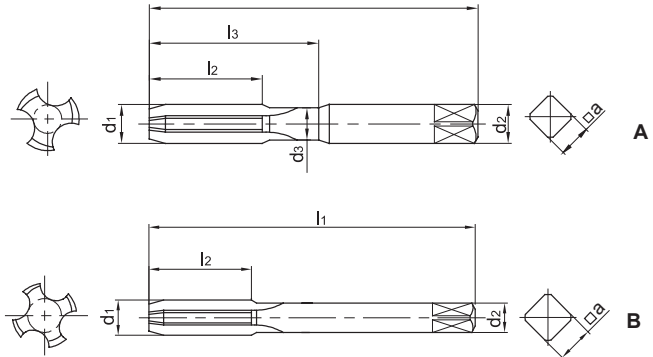

Type Typ	Taper length Anschlitt- länge	Basic dimension(mm) Basis Abmessungen										Number of teeth Zähne- anzahl	Grade Sorte YK40F	Coredrill Kernbohr d
		d <sub>1</sub>	P	d <sub>2</sub>	d <sub>3</sub>	l <sub>1</sub>	l <sub>2</sub>	l <sub>3</sub>	a×a	Thread-profile Gewinde- profil	Geometry Ausführung			
4202A-M3*0.5-6H	3P	M3	0.5	3.5	2.3	56	11	18	2.7	60°	A	3	●	2.5
4202A-M3*0.5-6HX	3P													
4202AS-M3*0.5-6H	1.5P	M3	0.5	3.5	2.3	56	11	18	2.7	60°	A	3	●	2.5
4202AS-M3*0.5-6HX	1.5P													
4202A-M4*0.7-6H	3P	M4	0.7	4.5	3.1	63	13	21	3.4	60°	A	3	●	3.3
4202A-M4*0.7-6HX	3P													
4202AS-M4*0.7-6H	1.5P	M4	0.7	4.5	3.1	63	13	21	3.4	60°	A	3	●	3.3
4202AS-M4*0.7-6HX	1.5P													
4202A-M5*0.8-6H	3P	M5	0.8	6	4	70	16	25	4.9	60°	A	3	●	4.2
4202A-M5*0.8-6HX	3P													
4202AS-M5*0.8-6H	1.5P	M5	0.8	6	4	70	16	25	4.9	60°	A	3	●	4.2
4202AS-M5*0.8-6HX	1.5P													
4202A-M6*0.75-6H	3P	M6	0.75	6	5	80	19	30	4.9	60°	A	3	●	5.25
4202A-M6*0.75-6HX	3P													
4202AS-M6*0.75-6H	1.5P	M6	0.75	6	5	80	19	30	4.9	60°	A	3	●	5.25
4202AS-M6*0.75-6HX	1.5P													
4202A-M6*1-6H	3P	M6	1	6	4.7	80	19	30	4.9	60°	A	3	●	5
4202AC-M6*1-6H	3P													
4202A-M6*1-6HX	3P	M6	1	6	4.7	80	19	30	4.9	60°	A	3	●	5
4202AS-M6*1-6H	1.5P													
4202ACS-M6*1-6H	1.5P	M6	1	6	4.7	80	19	30	4.9	60°	A	3	●	5
4202AS-M6*1-6HX	1.5P													
4202A-M7*1-6H	3P	M7	1	7	5.7	80	19	30	5.5	60°	A	3	●	6
4202AS-M7*1-6H	1.5P													
4202A-M8*1-6H	3P	M8	1	8	6.7	90	20	35	6.2	60°	A	3	●	7
4202AS-M8*1-6H	1.5P													



Solid Carbide drills  
Vollhartmetallbohrer

# Threading - Gewindebearbeitung

Solid Carbide Taps and cutter · Vollhartmetall-Gewindebohrer, -fräser

Type Typ	Taper length Anschnittlänge	Basic dimension(mm) Basis Abmessungen										Number of teeth Zähnezahl	Grade Sorte	Coredrill Kernbohr
		d1	P	d2	d3	l1	l2	l3	a×a	Thread-profile Gewindeprofil	Geometry Ausführung		YK40F	
4202A-M8*1.25-6H	3P	M8	1.25	8	6.4	90	22	35	6.2	60°	A	3	●	6.75
4202AC-M8*1.25-6H	3P													
4202A-M8*1.25-6HX	3P													
4202AS-M8*1.25-6H	1.5P													
4202ACS-M8*1.25-6H	1.5P													
4202AS-M8*1.25-6HX	1.5P													
4202A-M10*1-6H	3P	M10	1	10	8.7	100	20	39	8	60°	A	4	●	9
4202AS-M10*1-6H	1.5P													
4202A-M10*1.25-6H	3P	M10	1.25	10	8.4	100	24	39	8	60°	A	4	●	8.75
4202AS-M10*1.25-6H	1.5P													
4202A-M10*1.5-6H	3P	M10	1.5	10	8.1	100	24	39	8	60°	A	4	●	8.5
4202AC-M10*1.5-6H	3P													
4202A-M10*1.5-6HX	3P													
4202AS-M10*1.5-6H	1.5P													
4202ACS-M10*1.5-6H	1.5P													
4202AS-M10*1.5-6HX	1.5P													
4202A-M12*1.25-6H	3P	M12	1.25	9		110	29		7	60°	B	4	●	10.75
4202AS-M12*1.25-6H	1.5P													
4202A-M12*1.5-6H	3P	M12	1.5	9		110	29		7	60°	B	4	●	10.5
4202AS-M12*1.5-6H	1.5P													
4202A-M12*1.75-6H	3P	M12	1.75	9		110	29		7	60°	B	4	●	10.25
4202AC-M12*1.75-6H	3P													
4202A-M12*1.75-6HX	3P													
4202AS-M12*1.75-6H	1.5P													
4202ACS-M12*1.75-6H	1.5P													
4202AS-M12*1.75-6HX	1.5P													
4202A-M14*1.5-6H	3P	M14	1.5	11		110	30		9	60°	B	4	●	12.5
4202AS-M14*1.5-6H	1.5P													
4202A-M14*2-6H	3P	M14	2	11		110	30		9	60°	B	4	●	12
4202AS-M14*2-6H	1.5P													
4202A-M16*1.5-6H	3P	M16	1.5	12		110	32		9	60°	B	4	●	14.5
4202AS-M16*1.5-6H	1.5P													
4202A-M16*2-6H	3P	M16	2	12		110	32		9	60°	B	4	●	14
4202A-M16*2-6HX	3P													
4202AS-M16*2-6H	1.5P													
4202AS-M16*2-6HX	1.5P													

## Material Overview · Material Übersicht

✓ = Very suitable · Sehr empfohlen  
 ✓ = Suitable · Empfohlen

Grade Sorte	Workpiece material · Werkstückstoff									
	Mild steel Baustahl HB≤180	Carbon steel Alloy Steel Kohlenstoff-, Legierter Stahl	Hardened steel · Gehärteter Stahl			Stainless steel Rostfreier Stahl	Cast iron Gusseisen	Nodular cast iron GGG Kugelgraphitguss	Aluminum alloy Aluleg.	Copper alloy Kupferleg.
YK40F									✓	

Code key C 156  
ISO Kennzeichen

Cutting data C172  
Schnittdaten

Technical Information C173-174  
Technische Information.

Non-standard tailor made C175  
Bestellformular für Sonderwerkzeuge

# Threading · Gewindebearbeitung

Solid Carbide Taps and cutter · Vollhartmetall-Gewindebohrer, -fräser

## 4111

### Thread milling cutter with straight shank Gewindefräser mit Zylinderschaft

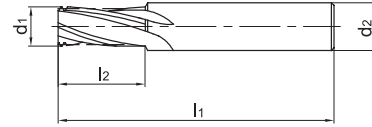

Type Typ	Basic dimension (mm) Basis Abmessungen						Number of teeth Zähnezahl	Grade Sorte		Coredrill Kernbohr d
	D	d <sub>1</sub>	P	d <sub>2</sub>	l <sub>1</sub>	l <sub>2</sub>		KTG4015	YK40F	
4111-M3*0.5	M3	2.35	0.5	4	50	6	3	●	○	2.5
4111-M4*0.7	M4	3.15	0.7	4	50	8	3	●	○	3.3
4111-M5*0.5	M5	4.3	0.5	6	50	10	3	●	○	4.5
4111-M5*0.8	M5	4	0.8	6	50	10	3	●	○	4.2
4111-M6*0.75	M6	5	0.75	6	60	12	4	●	○	5.25
4111-M6*1	M6	4.75	1	6	60	12	4	●	○	5
4111-M8*1	M8	6.65	1	8	60	16	4	●	○	7
4111-M8*1.25	M8	6.45	1.25	8	60	16	4	●	○	6.75
4111-M10*1	M10	8.55	1	10	75	20	4	●	○	9
4111-M10*1.5	M10	8.1	1.5	10	75	20	4	●	○	8.5
4111-M12*1.25	M12	10.25	1.25	12	75	24	4	●	○	10.75
4111-M12*1.75	M12	9.75	1.75	12	75	24	4	●	○	10.25
4111-M14*1	M14	12.35	1	14	75	20	4	●	○	13
4111-M14*1.5	M14	11.9	1.5	14	75	28	4	●	○	12.5
4111-M14*2	M14	11.4	2	14	75	28	4	●	○	12
4111-M16*2	M16	13.3	2	16	90	32	6	●	○	14
4111-M18*1	M18	16.15	1	18	90	20	6	●	○	17
4111-M18*2.5	M18	14.75	2.5	18	90	36	6	●	○	15.5
4111-M20*2	M20	17.1	2	18	100	40	6	●	○	18
4111-M20*2.5	M20	16.65	2.5	18	100	40	6	●	○	17.5

#### Material Overview · Material Übersicht

✓ = Very suitable · Sehr empfohlen  
 ✓ = Suitable · Empfohlen

Grade Sorte	Workpiece material · Werkstückstoff									
	Mild steel Baustahl HB≤180	Carbon steel Alloy Steel Kohlenstoff- Legierter Stahl	Hardened steel · Gehärteter Stahl			Stainless steel Rostfreier Stahl	Cast iron Gusseisen	Nodular cast iron GGG Kugelgra- phitguss	Aluminum alloy Aluleg.	Copper alloy Kupferleg.
KTG4015	✓	✓	✓				✓	✓		
YK40F							✓		✓	✓

Code key C 156  
ISO Kennzeichen

Cutting data C172  
Schnittdaten

Technical Information C173-174  
Technische Information.

Non-standard tailor made C175  
Bestellformular für Sonderwerkzeuge